

**NEC**

ND-60192-001(E)-03

Issue 3, June 2008

# PasoWings

**Mobile WiMAX**

**Installation Manual**

**Base Station**

**IMN:BS**

**NEC Corporation**

Copyright 2007, 2008 by NEC Corporation

All rights reserved. No part of this publication may be reproduced, stored in a retrieval system, or transmitted, in any form or by any means, including electronic, mechanical, photographic, or magnetic, without prior written permission of the publisher.

Trademarks:

All designations used in this document can be trademarks, the use of which by third parties for their own purposes violates the rights of their owners.

Printed in Japan

## Preface

---

### **Purpose of This Document**

This manual describes the procedures at Base Station (BS) site in PasoWings, the NEC Mobile WiMAX system, starting from installation of IDU/ODU up to power-on.

### **Structure of This Document**

#### **Section 1 Introduction**

This section describes the basic conditions of a BS site and the labels.

#### **Section 2 IDU Installation**

This section describes the IDU types and installation procedures.

#### **Section 3 ODU Installation**

This section describes the ODU types and installation procedures.

#### **Section 4 BS Connection Diagrams**

This section describes the IDU/ODU cable connections.

#### **Section 5 BS Power-On**

This section describes the power-on procedures of the whole BS.

#### **Section 6 Appendix - Typical Installation Drawing**

This section describes the typical installation drawing of BS site.

### Document Amendment Record

---

<b>Issue</b>	<b>Date</b>	<b>Remarks</b>
1	2007/Dec	First issue
2	2008/Jan	Second issue
3	2008/Jun	Third issue (Section 6 is added.)

# Table of Contents

---

- 1. Introduction..... 8**
  - 1.1 Overview .....8**
  - 1.2 Conformed Standards.....8**
  - 1.3 Site Requirements .....9**
  - 1.4 Environmental Conditions .....9**
  - 1.5 Label Information .....10**
  - 1.6 Alert Symbol..... 11**
  - 1.7 Antenna Cable Attenuation Adjustment.....12**
  
- 2. IDU Installation..... 15**
  - 2.1 Cautions upon Installation .....15**
  - 2.2 IDU External View and Names .....16**
    - 2.2.1 IDU ..... 16
    - 2.2.2 NW INTFC Part.....18
    - 2.2.3 CHC Part.....18
  - 2.3 Installation Procedures .....19**
    - 2.3.1 Carrying by Personnel .....19
    - 2.3.2 Used Tool, Material and Tightening Torque .....19
    - 2.3.3 Mount Types .....20
      - 2.3.3.1 RACK Types..... 21
      - 2.3.3.2 Flange Position for Standard Mounting ..... 22
      - 2.3.3.3 Changing Flange Position from Standard to 125mm Offset ..... 23
      - 2.3.3.4 Flange Position for 125mm Offset..... 24
      - 2.3.3.5 Changing Flange Position from Standard to 50mm Offset..... 25
      - 2.3.3.6 Flange Position for 50mm Offset..... 26
    - 2.3.4 Mounting Procedure .....27
    - 2.3.5 Removal Procedure.....28
  - 2.4 External Connections.....29**
    - 2.4.1 External Connection Terminals.....29
    - 2.4.2 Optical Cable Insertion Procedure and Cautions .....30
      - 2.4.2.1 Insertion Procedure for Optical Cables..... 30
      - 2.4.2.2 Cautions on Handling Optical Cables..... 31
    - 2.4.3 Insertion Procedures for Connectors.....32
      - 2.4.3.1 Inserting Power Cable..... 32
      - 2.4.3.2 Inserting GPS-ANT Cable..... 33

- 2.4.3.3 Ground Connection..... 36
- 2.5 Power-On Procedures.....37**
- 2.6 Technical Data.....37**
- 3. ODU Installation ..... 38**
  - 3.1 Cautions upon Installation .....38**
  - 3.2 ODU External View and Names .....39**
    - 3.2.1 External View of ODU..... 39
    - 3.2.2 Dimensions and Interface Part Details..... 41
  - 3.3 Installation Procedures.....43**
    - 3.3.1 Carrying by Personnel ..... 43
    - 3.3.2 Places to Install This Equipment..... 43
    - 3.3.3 Used Tools, Materials and Tightening Torque ..... 43
    - 3.3.4 Mounting Procedure ..... 44
    - 3.3.5 Removal Procedure..... 45
  - 3.4 External Connections.....45**
    - 3.4.1 External Connection Terminals..... 45
    - 3.4.2 Insertion Procedures of Connectors ..... 45
      - 3.4.2.1 Power Cable Insertion Procedure ..... 46
      - 3.4.2.2 FG Cable Insertion Procedure ..... 47
      - 3.4.2.3 Antenna Terminal Cable Insertion Procedure ..... 48
      - 3.4.2.4 Optical Cable Insertion Procedure..... 50
      - 3.4.2.5 Cautions on Handling Optical Cables..... 51
      - 3.4.2.6 Waterproofing with Self-welding Tapes ..... 51
  - 3.5 Technical Data.....52**
- 4. BS Connection Diagrams ..... 53**
- 5. BS Power-On ..... 55**
- 6. Appendix - Samples of Installation Layouts and Materials..... 57**
  - 6.1 Site Layout.....57**
  - 6.2 Floor Layout.....61**
  - 6.3 Power Wiring Diagram.....62**
  - 6.4 Signal Wiring Diagram.....64**
  - 6.5 Bayface Layout.....66**
  - 6.6 Antenna Pole Samples .....67**
  - 6.7 ODU Mount Structure and Installation Material .....70**

**6.8 IDU Mount Structure .....74**  
**6.9 Piping and Pipe Rack.....75**

## 1. Introduction

### 1.1 Overview

The outline drawing of a Base Station (BS) is shown below.

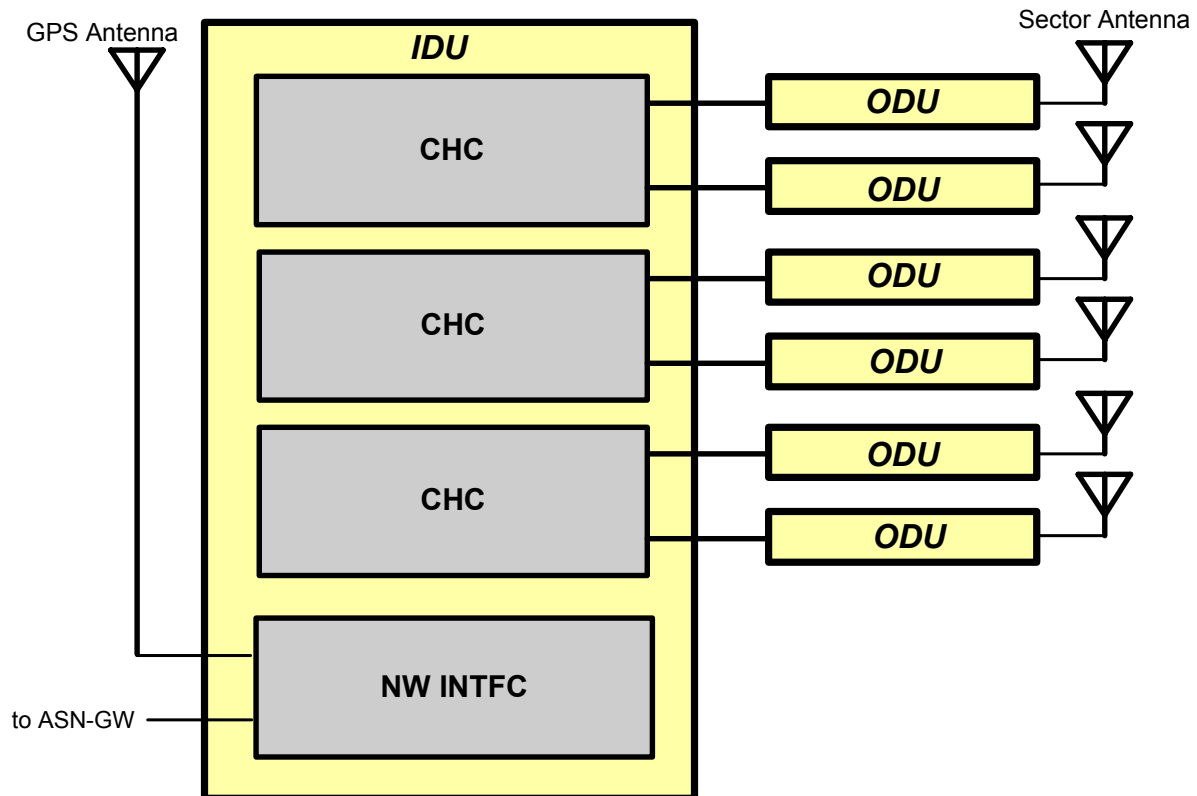

**Figure 1-1 BS Outline Drawing (Example: 3-sector configuration)**

This manual describes the installation procedures for Indoor Unit (IDU) and Outdoor Unit (ODU).

This manual does not include the installation procedure for sector antenna. Refer to “Sector Antenna Installation Manual” (ND-60198-001(E)).



**WARNING:** This is a class A product. In a domestic environment this product may cause radio interference in which case the user may be required to take adequate measures.

### 1.2 Conformed Standards

This system conforms to the requirements of R&TTE (1999/5/EC) directive. Also, evaluation tests have been performed based on the following standards:

- EN60950-1/EN60950-22/EN50385
- EN301489-1/EN301489-4
- EN302326-2



### 1.3 Site Requirements

This system is intended to be installed and used in a Telecommunication Centre and similar location.

Prior to the commencement of installation, the construction of the room, in that this system is to be placed, should be complete and in appropriate condition.

- This equipment shall be installed at a restricted access location <sup>\*1</sup> by a service person. <sup>\*2</sup>
- This installation location should meet following conditions:
  - Installation of doors, windows, room lights, wall sockets, floor covers, air-conditioner, battery ventilation
  - DC-48V power supply equipment
  - The lightning protections and grounding systems must be completed.
  - High security system to avoid unauthorized access
  - Openings in wall or ceiling or floor, if required, must be completed.
  - Walls and ceilings should have been painted.

<sup>\*1</sup>: RESTRICTED ACCESS LOCATION is defined as,  
a location for equipment where both of the following paragraphs apply:

- access can only be gained by SERVICE PERSONS or by USERS who have been instructed about the reasons for the restrictions applied to the location and about any precautions that shall be taken; and
- access is through the use of a TOOL or lock and key, or other means of security, and is controlled by the authority responsible for the location.

<sup>\*2</sup>: SERVICE PERSON means,  
a person having appropriate technical training and experience necessary to be aware of hazards to which that person may be exposed in performing a task and of measures to minimize the risks to that person or other persons.

### 1.4 Environmental Conditions

The location of a site may directly effect the correct operation of the BS. In areas of excessive salt contamination situations it is recommended not to place the BS close to coastal areas in order to avoid shorter maintenance intervals.

It is recommended to keep a distance of about > 1.6 km from the coast. Enclosures on coastal sites should not be installed with the air intakes facing directly into prevailing sea winds or spray.

Sites located close to excessive airborne dust clouds i.e. cement, coal deposits etc. should also be minimized in order to avoid contamination of the cooling system and increased maintenance.

The installation nearby emissions of hydrocarbon gas (e.g. chimney, exhaust air outlets) is not recommended in order to avoid shorter service intervals of the membrane filters.

## 1.5 Label Information

On the equipments forming the BS, labels indicating the environmental and safety standards are attached.

- Waste Electrical and Electronic Equipment (WEEE) directive

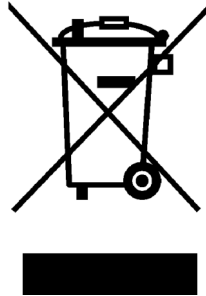

All electrical and electronic products should be disposed of separately from the municipal waste stream via designated collection facilities appointed by the government or the local authorities.

The correct disposal and separate collection of your old appliance will help prevent potential negative consequences for the environment and human health. It is a precondition for reuse and recycling of used electrical and electronic equipment.

For more detailed information about disposal of your old appliance, please contact your sales representative.

The statements quoted above are only fully valid for equipment which is installed in the countries of the European Union and is covered by the directive 2002/96/EC.

Countries outside the European Union may have other regulations regarding the disposal of electrical and electronic equipment.

- Laser Warning



To avoid damage to health, you must observe the regulations regarding protection against radiation from laser devices. You must always use dedicated laser-protective goggles. Never look into open fiber-optic cable ends, as this may damage your eyes.

- Rotating Parts Warning Label



FUN continues rotating for a while after removing FUN UNIT. Do not touch it.

## 1.6 Alert Symbol



The instructions marked by symbol are especially important for safety. Always follow the instructions.

## 1.7 Antenna Cable Attenuation Adjustment



### WARNING

The electromagnetic field (EMF) generated by a Base Station (BS) could have detrimental effects on human health in areas very close to the BS antenna. Excessive EMF exposure by the installation/service personnel must be avoided. For installation and maintenance activities it is important to know the EMF compliance boundaries in antenna areas.

The safety distances in each spatial dimension determine the **Compliance Boundary** according to EN 50385.

The limits for EMF exposure of the general public are defined in ICNIRP Guidelines and European Council Recommendation 1999/519/EC:

- **BS . . . 10 W/m<sup>2</sup> (Power flux density)**

At every point of interest outside the compliance boundary the EMF level generated by a Base Station shall remain below the above-mentioned limits.

The following Base Station parameters were used for calculations of compliance boundaries in accordance with EN 50383:

**Table 1-1 Base Station (3.5GHz) Parameters**

TX frequency band		3.5GHz
BS RF output power (maximum)		+38dBm
Sector antenna	Main beam antenna gain	17dBi
	Antenna vertical side lobe suppression	>20dB
	Antenna back lobe suppression	>20dB
	Height of antenna panel	0.9m
	Outer diameter AD of antenna panel arrangement	1m

**Table 1-2 Base Station (2.5GHz) Parameters**

TX frequency band		2.5GHz
BS RF output power (maximum)		+38dBm
Sector antenna	Main beam antenna gain	17dBi
	Antenna vertical side lobe suppression	>20dB
	Antenna back lobe suppression	>20dB
	Height of antenna panel	1.2m
	Outer diameter AD of antenna panel arrangement	1m

Please use the following calculated data of Compliance Boundary by installation for making a restricted access area with sufficient safety distance, and to ensure that people are outside this Compliance Boundary.

- 1-sector BS with 1 TX antenna per sector, on one tower

The antenna arrangement and compliance boundary shape is shown in Figure 1-2.

Lhf	2.1m
Lhb	0.66m
Lv	0.66m

(Include safety margin (0.5m))

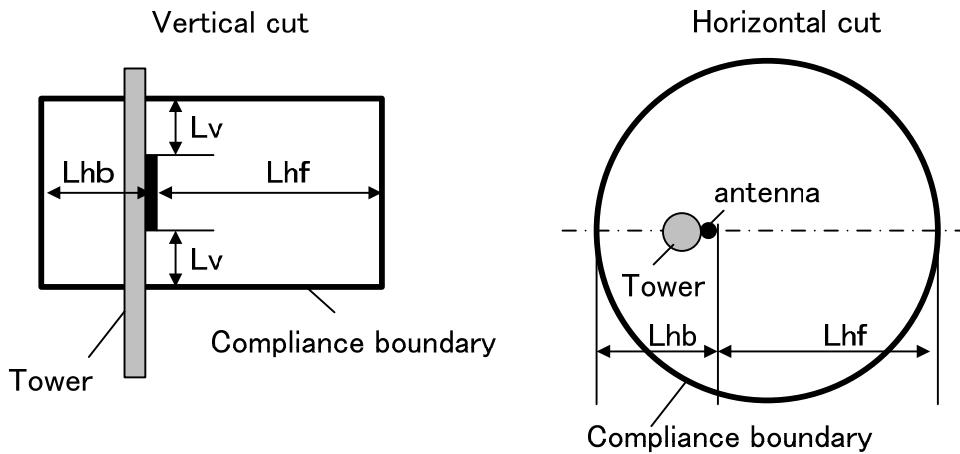

Figure 1-2 1-sector BS with 1 TX antenna per sector, on one tower

- 3-sector BS with 1 TX antenna per sector, on one tower

The antenna arrangement and compliance boundary shape is shown in Figure 1-3.

Lhf	2.1m
Lhb	0.66m

(Include safety margin (0.5m))

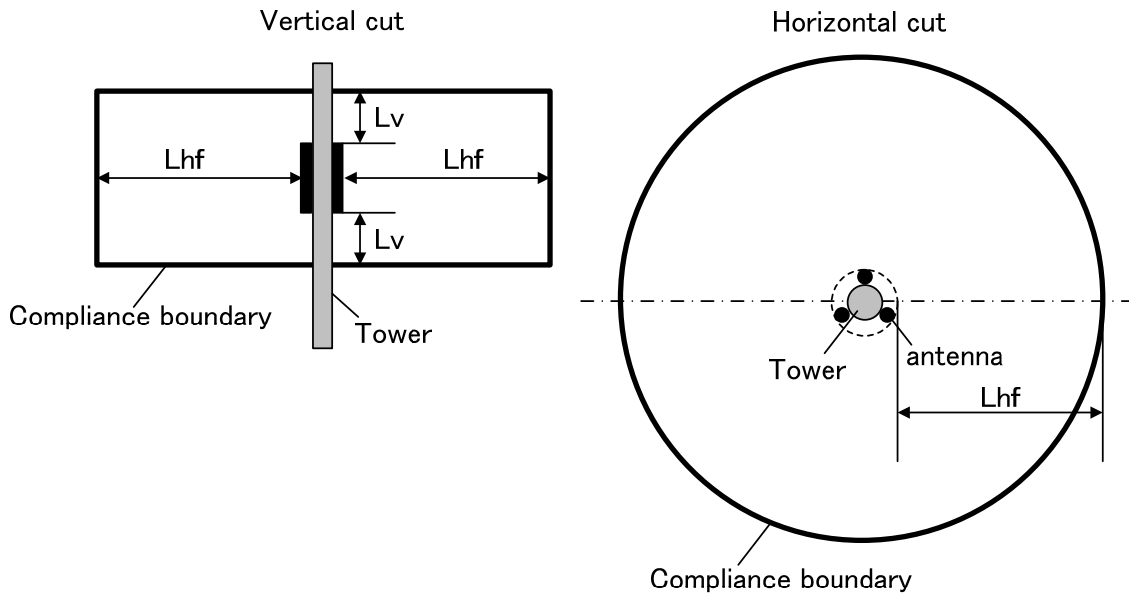

**Figure 1-3 3-sector BS with 1 TX antenna per sector, on one tower**

## 2. IDU Installation

---

### 2.1 Cautions upon Installation

- **AUTION FOR HIGH ENERGY:** this IDU Unit is using DC-48V for power supply. Please shut down the power supply, before open the enclosure. And pay attention for the risk of high energy by service, when the power is on.
- Install the Rack to mount the IDU equipment to a level surface, with the leveling processing performed.
- Be careful while carrying the IDU equipment, since dropping may break the equipment
- Follow the procedures in section 2.3 to install the IDU equipment.
- Do not carry the IDU equipment with the cables connected.

## 2.2 IDU External View and Names

### 2.2.1 IDU

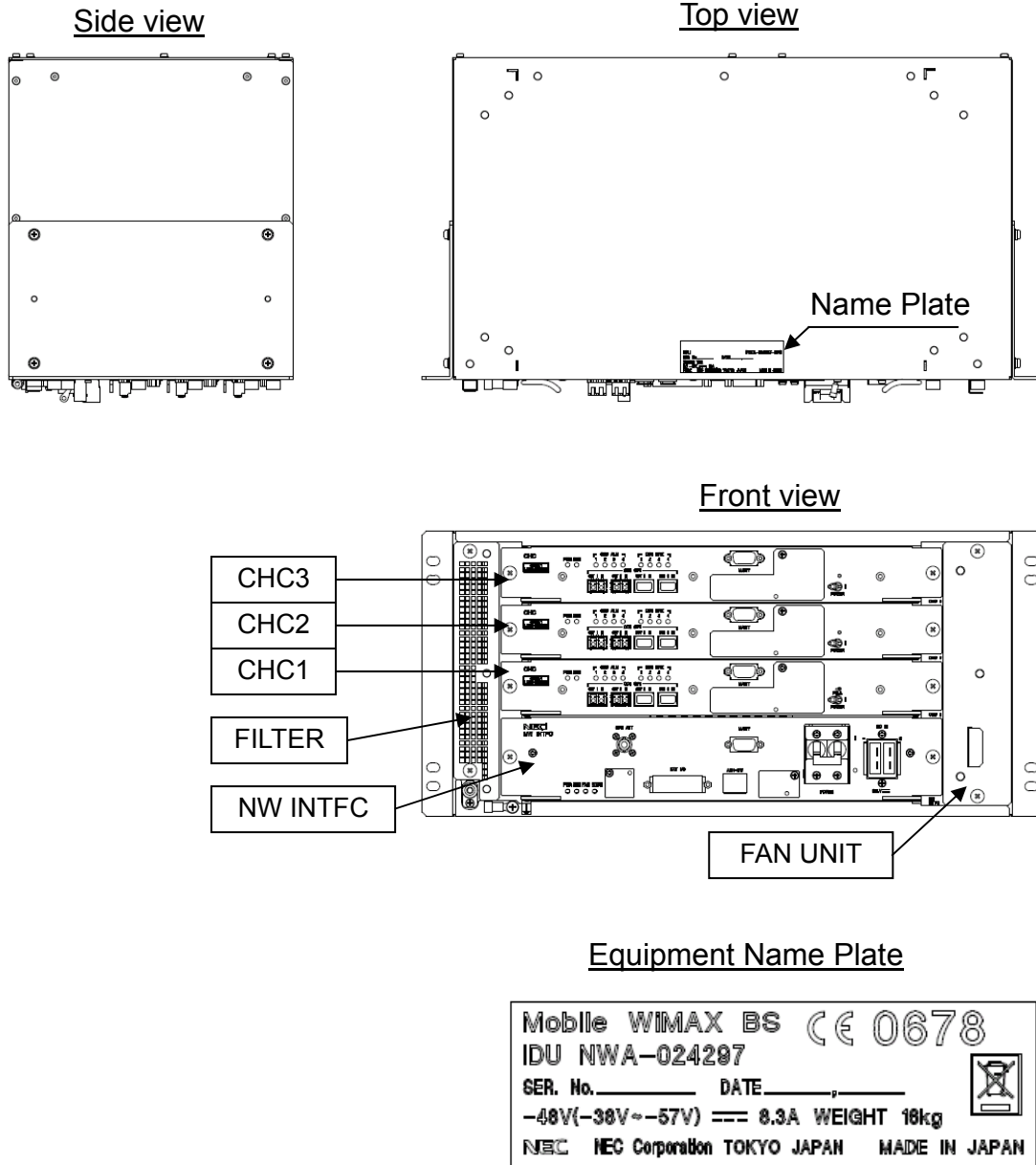

Figure 2-1 External View (IDU for 3-Sector Configuration)



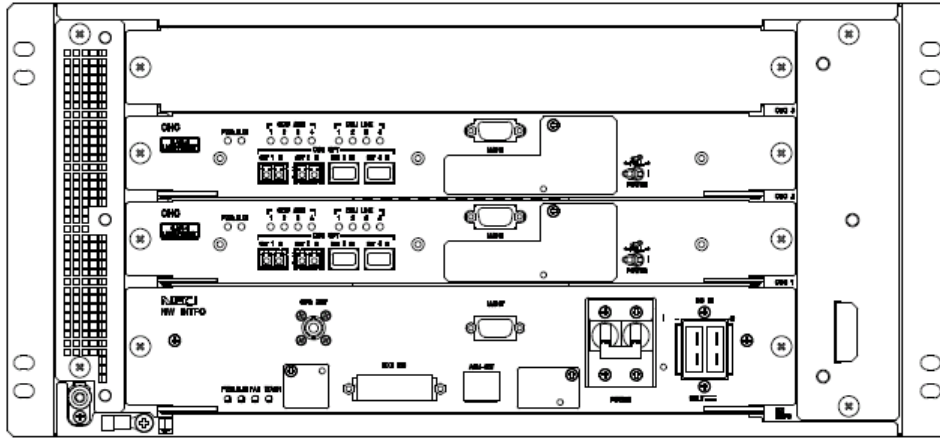

Figure 2-2 External View (IDU for 2-Sector Configuration)

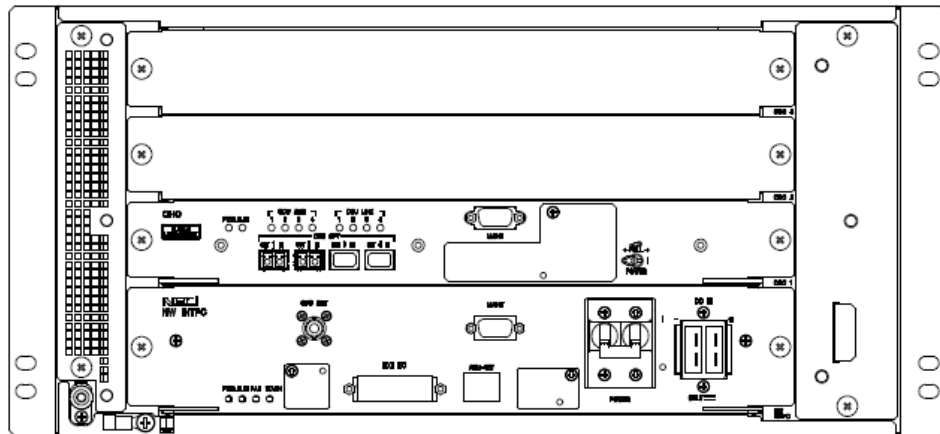

Figure 2-3 External View (IDU for 1-Sector Configuration)

2.2.2 NW INTFC Part

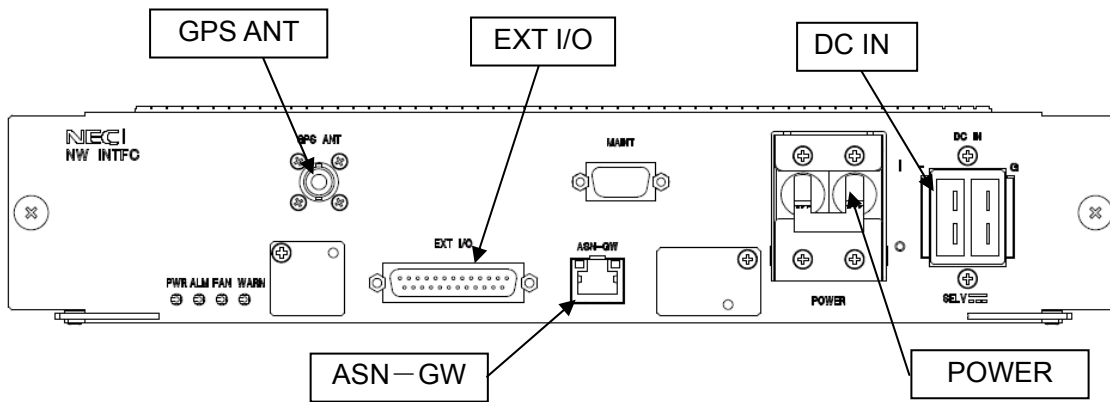

Figure 2-4 External View (NW INTFC)

2.2.3 CHC Part

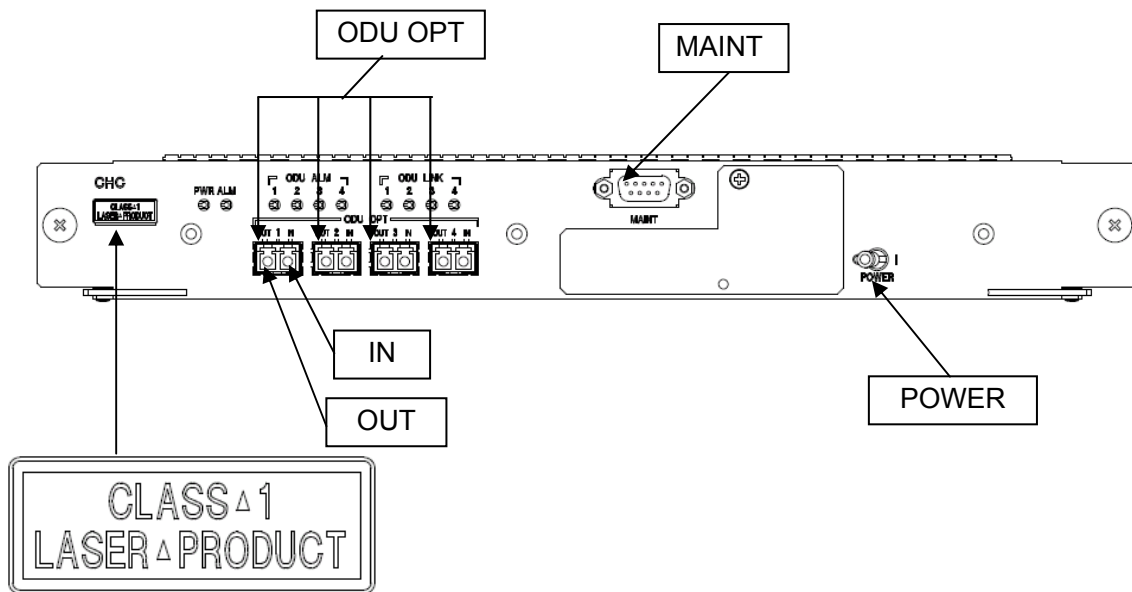

Figure 2-5 External View (CHC)

## 2.3 Installation Procedures

### 2.3.1 Carrying by Personnel

The following shows the cautions when carrying this equipment manually.

The maximum mass of IDU is 16kg. When carrying this equipment, always place your hands on the bottom surface. If parts other than the bottom surface are held, you may deform or break the equipment.



When carrying this equipment, be careful not to hurt your hands with the projections, external connection cables, etc.

### 2.3.2 Used Tool, Material and Tightening Torque

**Table 2-1 Used Tool and Material**

Tool and Material	Use	Quantity
Screw driver	For M5	1
M5x12 Screw	To mount the Rack	4

**Table 2-2 Tightening Torque**

Size	Tightening Torque {N – m}
M5	2.64

**2.3.3 Mount Types**

IDU supports three types of Racks. Rack mounting brackets are attached before shipment.

At shipment, IDU is set at the standard flange position. By adjusting the flange position, IDU can be tuned to fit each Rack type. The following figure shows the different flange positions when mounting the IDU to each Rack type.

Plane Views of IDU on Rack

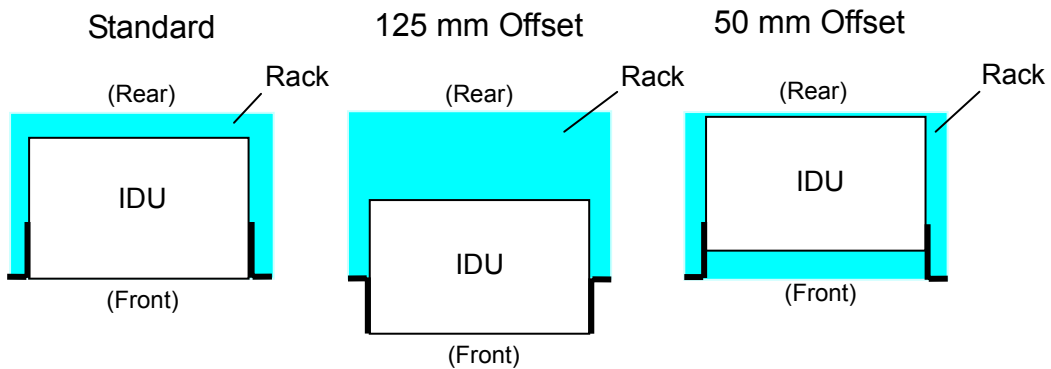

Figure 2-6 IDU Mount Types

The following figure shows the required space when installing IDU.

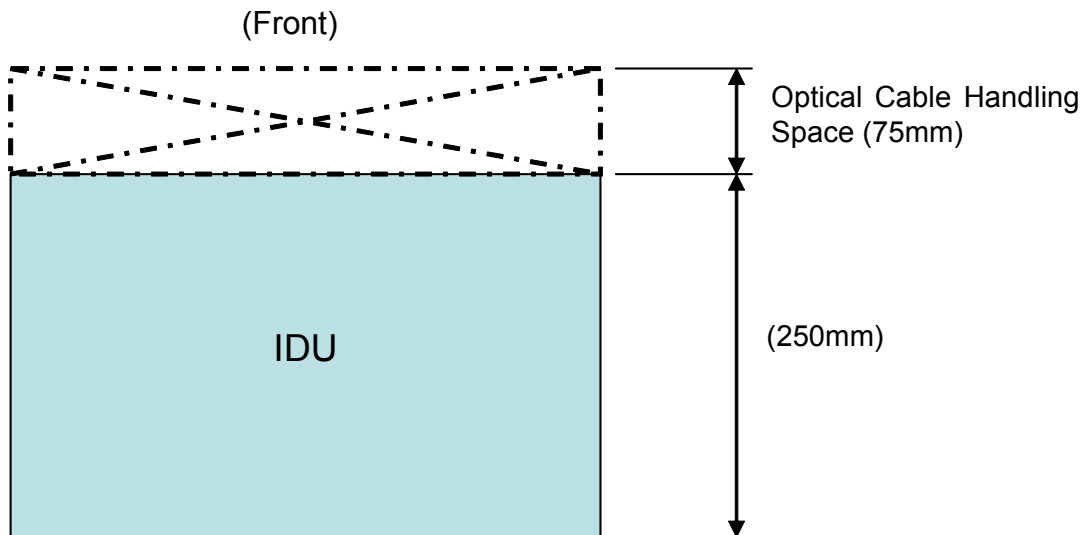

Figure 2-7 Required Space to Install IDU

In the following section, the adaptation of the Racks to the flange positions is shown and the procedure to change the flange position is described.

**2.3.3.1 RACK Types**

**Table 2-3 Open Rack Type Adaptations**

	Mounting Pattern	
	Standard	125mm Offset
19 inch	Yes	Yes
19 inch IEC60917 (JIS C6010)	Yes	Yes
ETSI	Yes	Yes

**Table 2-4 Closed Rack Type Adaptations**

Rack Type	Width	D1 Front Side Mounting Area	D2 Rear Side Mounting Area	Mounting Pattern	
				Standard	50mm Offset
19 inch	400 (D1=60)	60	280	No	No
	400 (D1=120)	120	160	No	No
	600 (D1=60)	60	480	No	Yes
	600 (D1=120)	120	360	Yes	Yes
19 inch IEC60917 (JIS C6010)	300	25	225	Yes	Yes
	400	25	325	N/A (*)	Yes
	600	25	525	N/A (*)	Yes
ETSI	300	40	240	No	No
	600	75	470	Yes	Yes

\* 50mm offset

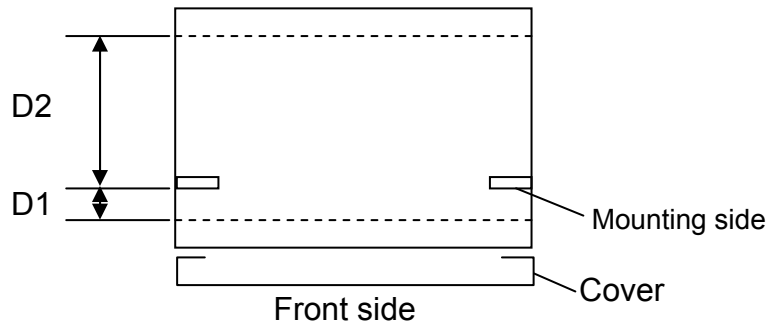

**Figure 2-8 Dimensions of Supported Rack**

### 2.3.3.2 Flange Position for Standard Mounting

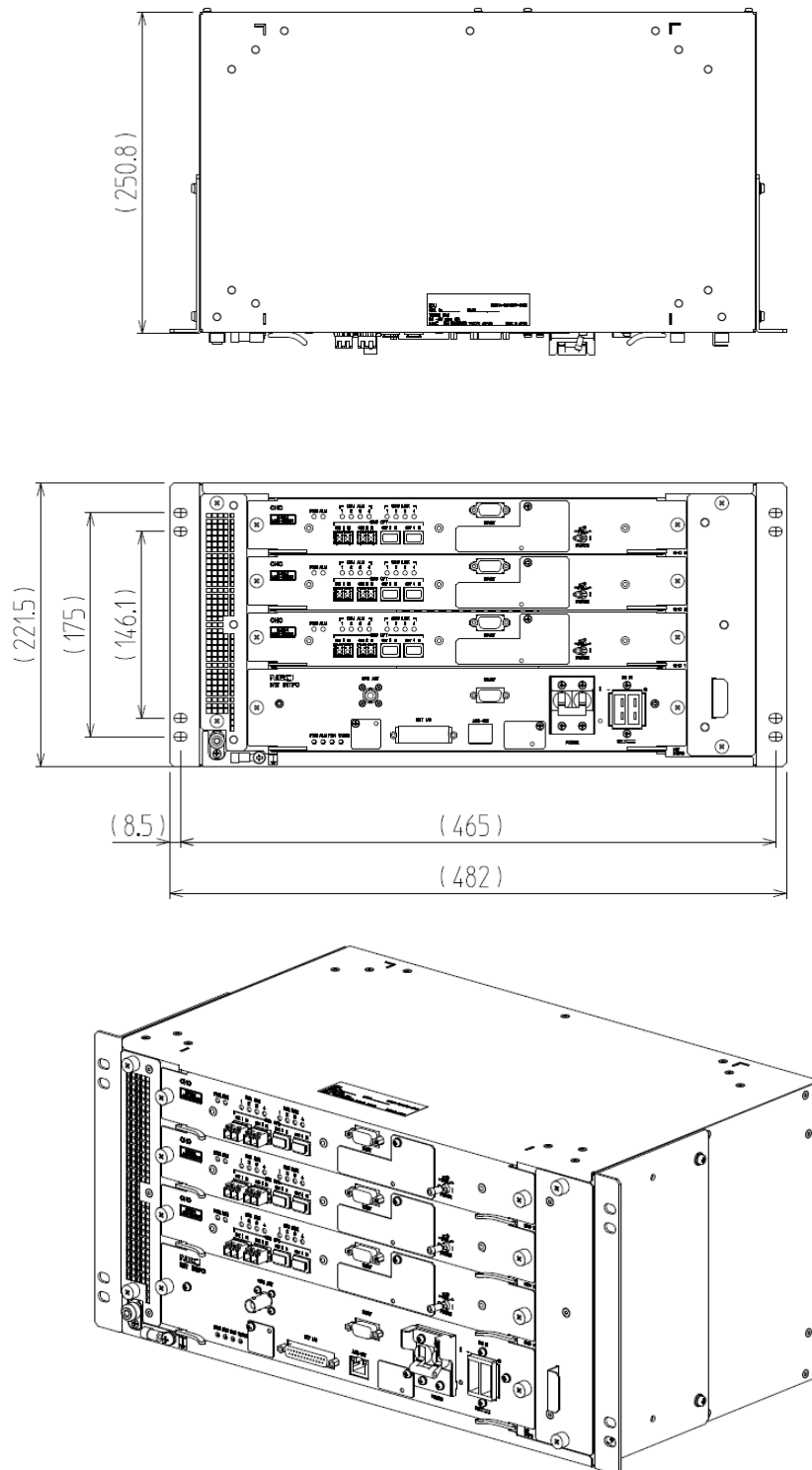
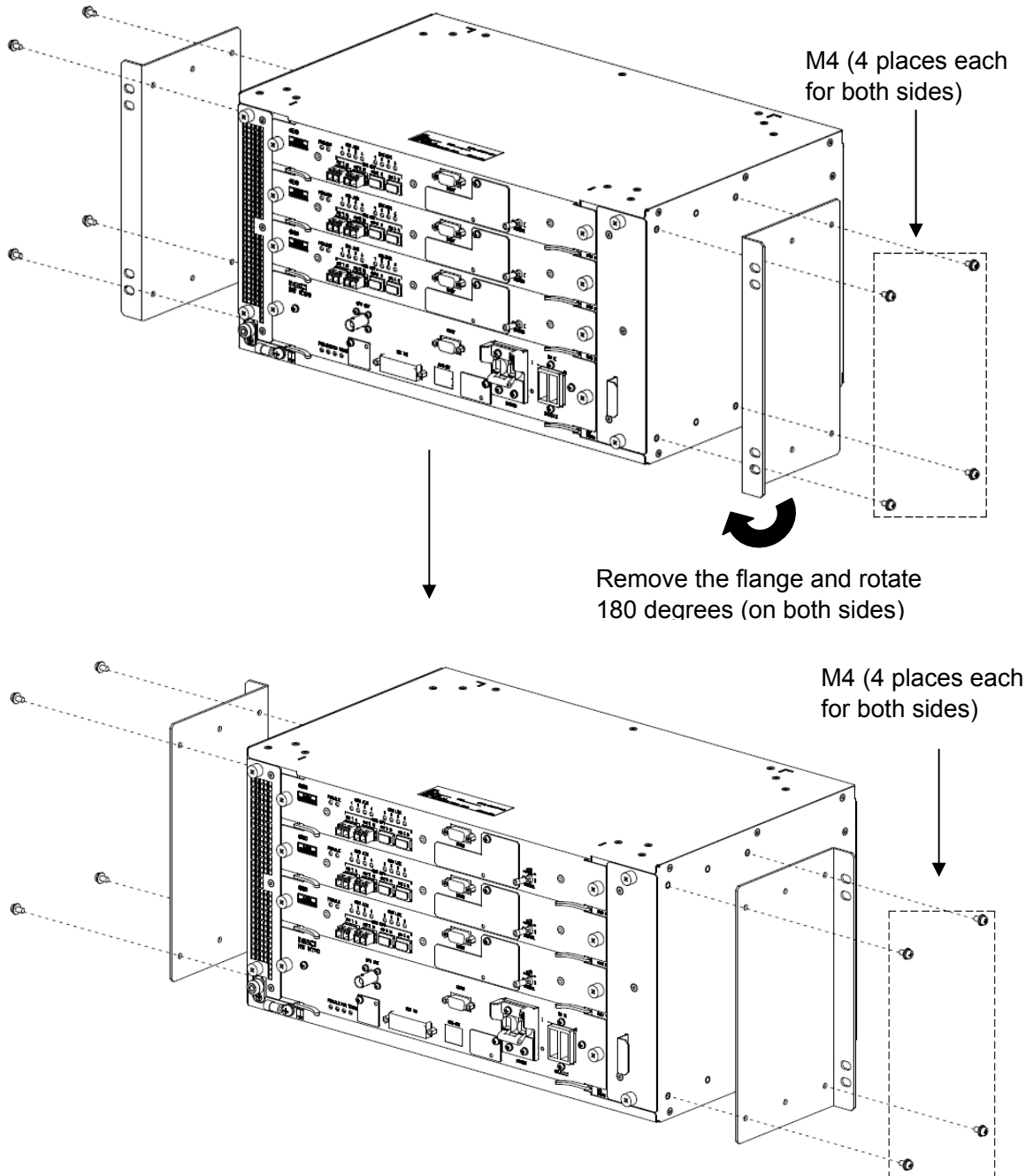

Figure 2-9 Mounting Interface (Standard Mounting)

**2.3.3.3 Changing Flange Position from Standard to 125mm Offset**

By changing the flange mounting method as shown in the following figure, the standard mounting 19 inch rack type can be changed to JIS C6010 rack type.



**Figure 2-10 Changing Flange Positions (19 Inch Rack to JIS C6010 Rack)**

### 2.3.3.4 Flange Position for 125mm Offset

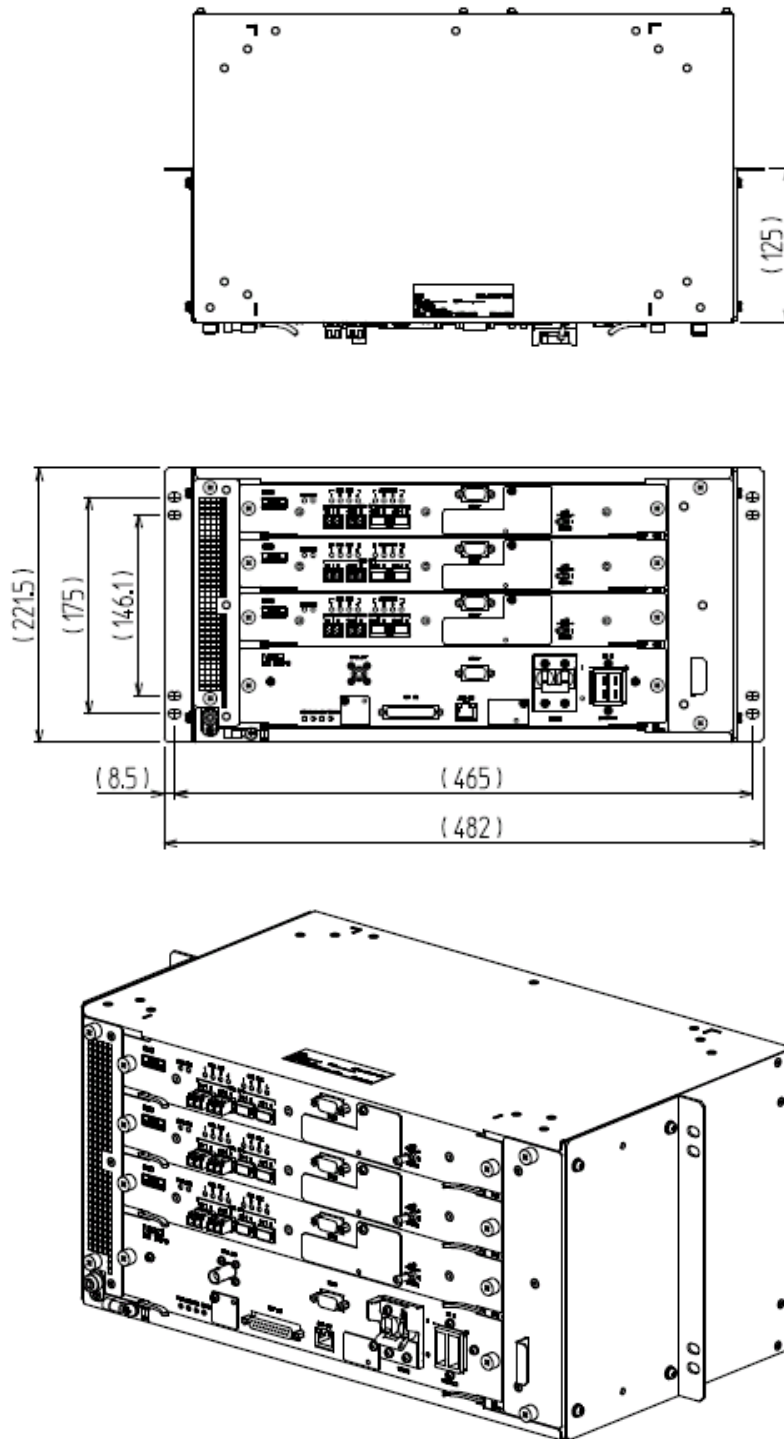
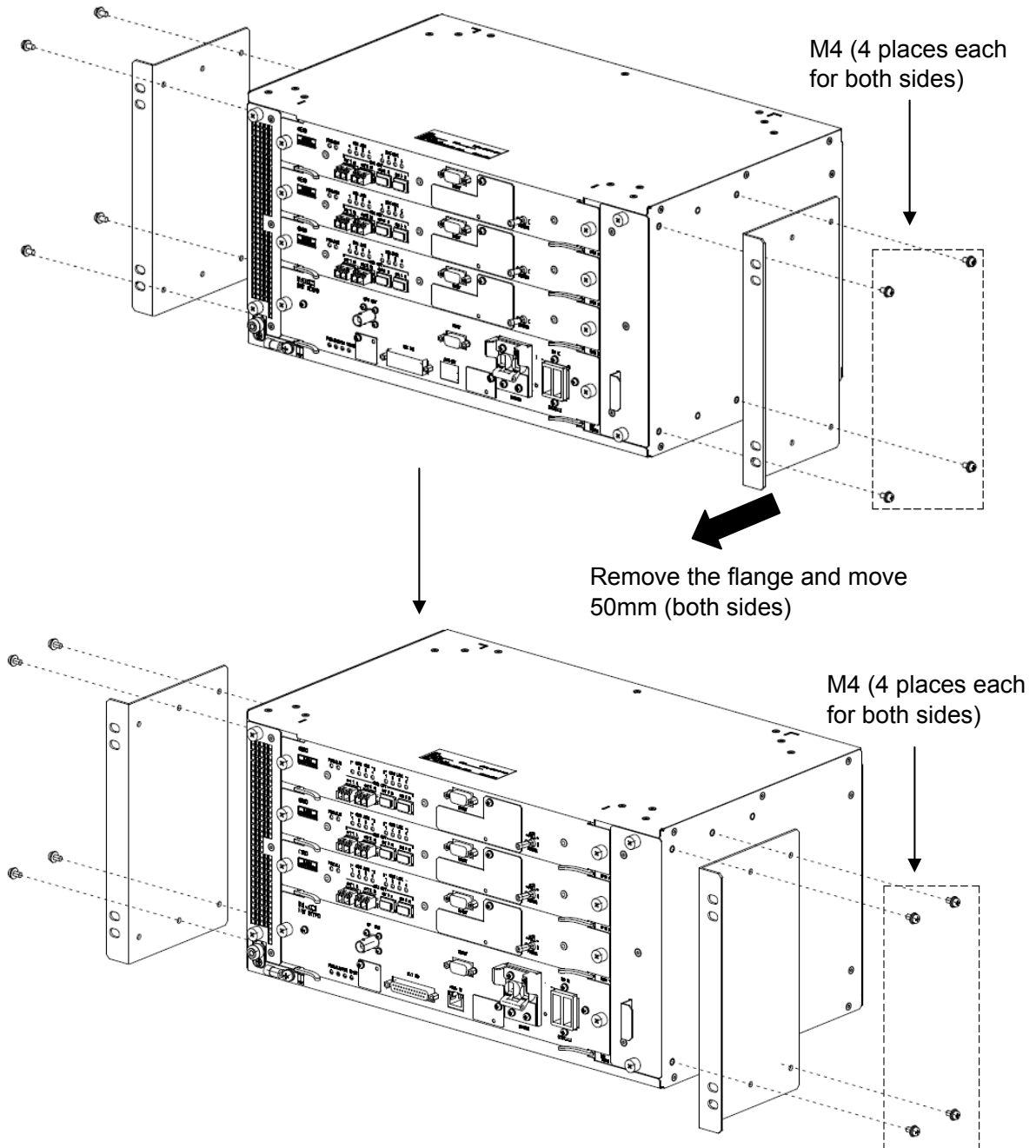

Figure 2-11 Mounting Interface (125mm Offset Mounting)



### 2.3.3.5 Changing Flange Position from Standard to 50mm Offset

By changing the flange mounting method as shown in the following figure, the standard mounting 19 inch rack type can be changed to JIS C6010 rack type



**Figure 2-12 Changing Flange Positions (19 Inch Rack to JIS C6010 Rack)**

**2.3.3.6 Flange Position for 50mm Offset**

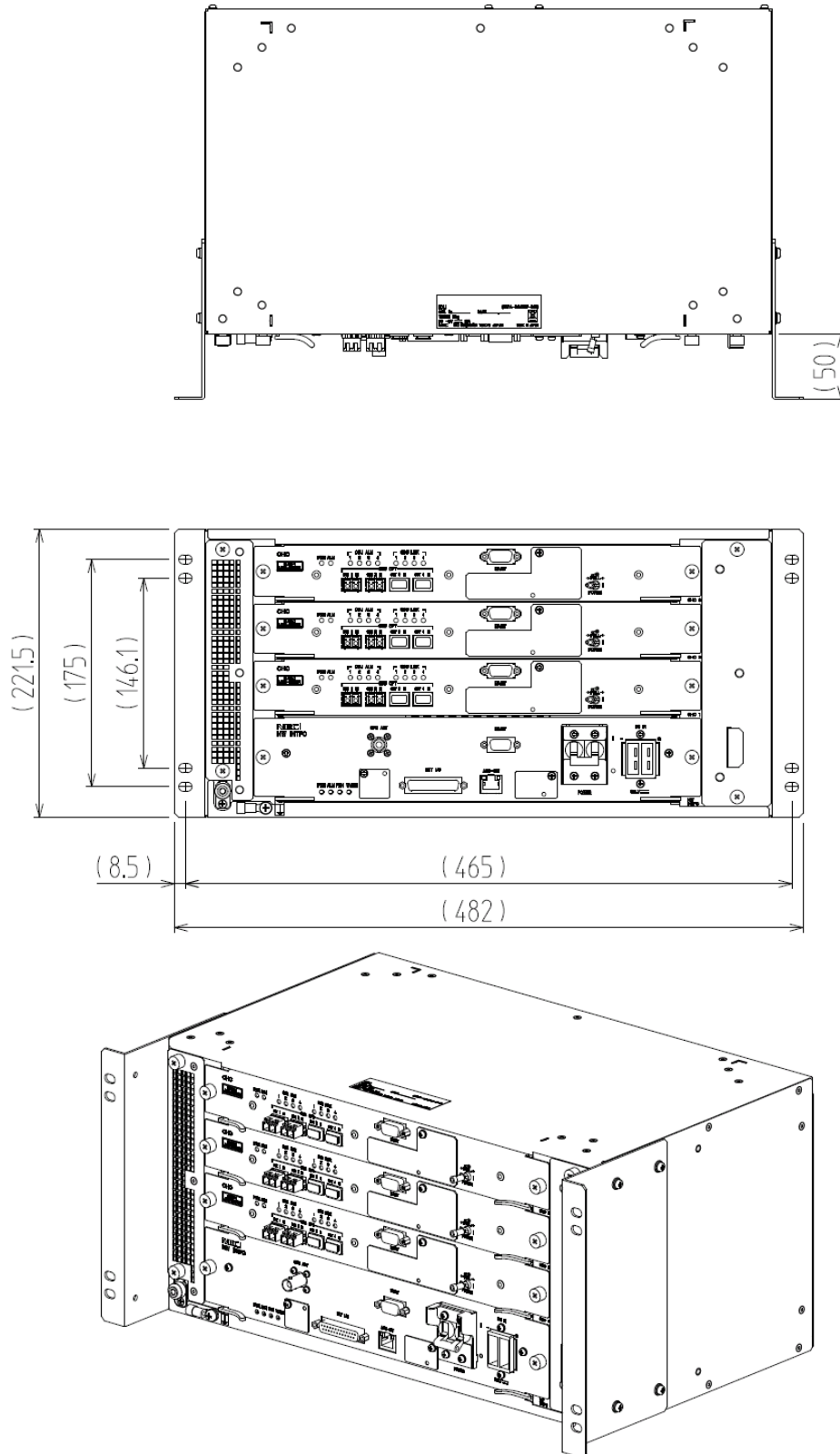

**Figure 2-13 Mounting Interface (50mm Offset Mounting)**

### 2.3.4 Mounting Procedure

When mounting the equipment to the Rack, use M5x12 screws (4 places) you prepared (not included in the kit) to fix the equipment. Note that the hole positions differ for each rack.

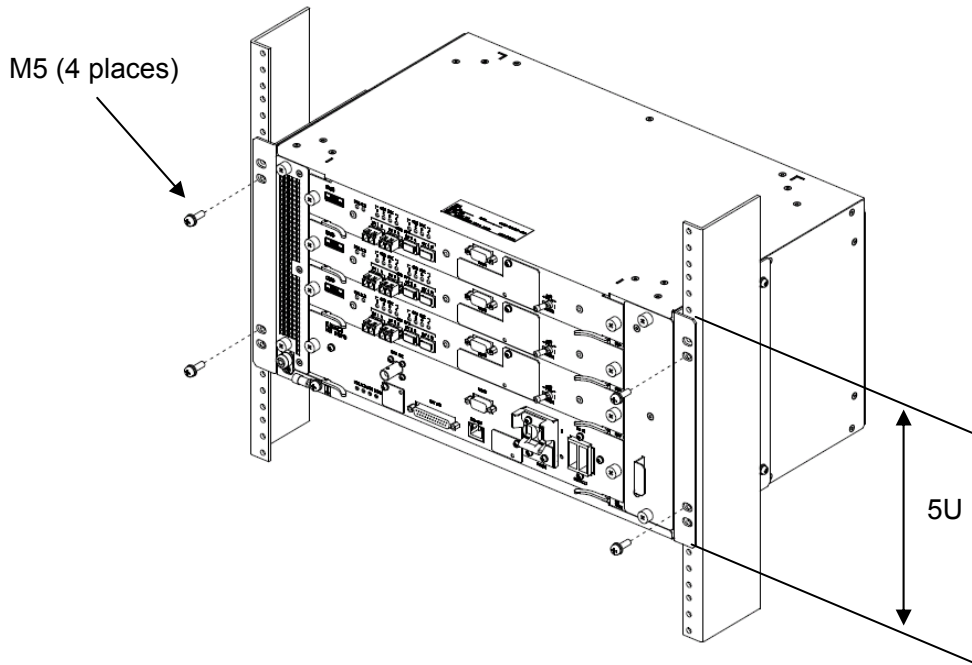

Figure 2-14 19 Inch Rack Mounted

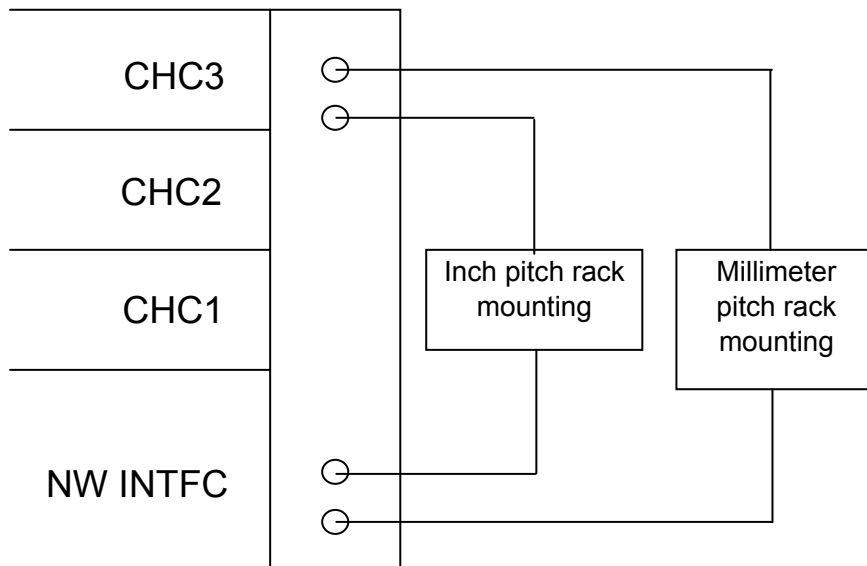

Figure 2-15 Mounting Various Racks

### 2.3.5 Removal Procedure

Remove the equipment by following the installation procedure from the end.



**Equipment weighs 16kg, so when removing it hold the bottom surface firmly and be careful not to drop it.**

## 2.4 External Connections

### 2.4.1 External Connection Terminals

The following describes the external connection terminals.

**Table 2-5 Power Input Terminal Connector**

No.	Items	Remarks	Q'ty
1	DC Power Terminal Connector <b>DC-48V IN</b>	On the equipment side: 1-917809-2 Tab housing (panel mount) by TycoAMP: 1 917805-2 Tab contact by TycoAMP: 4	1 set
		On the cable side: 1-917807-2 Receptacle housing by TycoAMP: 1 316041-2 Receptacle contact by TycoAMP: 4	1 set

**Table 2-6 Always-Connected Connectors (Equipment Side)**

No.	Items	Remarks	Q'ty
1	LAN Port <b>ASN-GW</b>	RJ-45_J 10/100/1000 Base-T	1
2	GPS Port <b>GPS ANT</b>	BNC-J 50Ω	1
3	External In/Out Port <b>EXT I/O</b>	D-sub25pin P 4 outputs: Relay interface 4 inputs: Photo coupler interface Inch standard (millimetre on demand), female	1
4	Optical Connector <b>ODU OPT</b>	SFP Module (Max. 4 per CHC)	12 (max)

## 2.4.2 Optical Cable Insertion Procedure and Cautions

### 2.4.2.1 Insertion Procedure for Optical Cables

OPT connector of the IDU equipment used for ODU connection is of LC connector type. Check that the optical cable you prepared has LC connector on the side inserted to this equipment, and insert the connector till you hear a click.

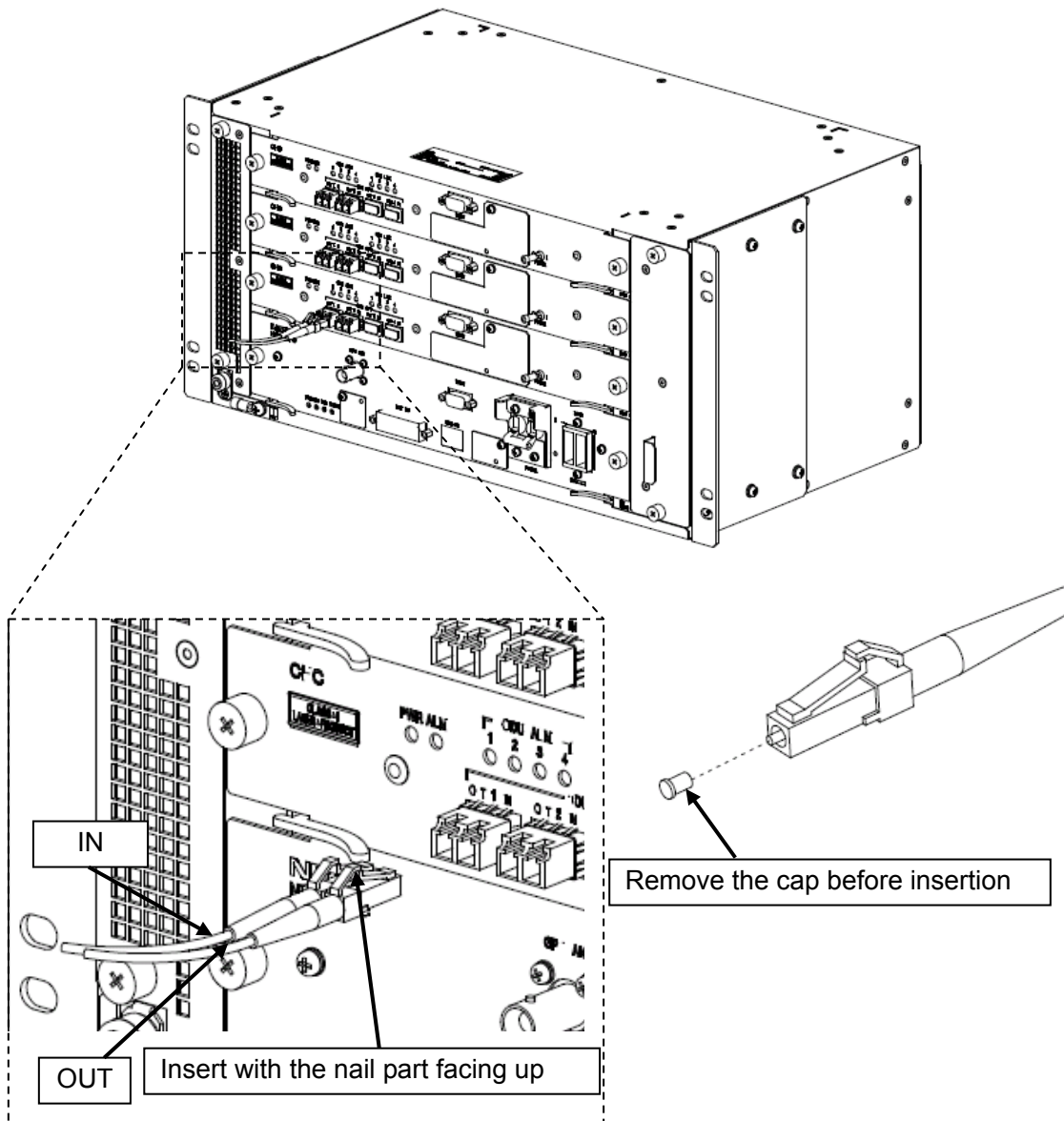

Figure 2-16 Optical Cable Connection Details

### 2.4.2.2 Cautions on Handling Optical Cables

- For the optical cables to connect to **OPT** connectors of this equipment, leave surplus length so that the bend radius is not below the specified minimum cable bend radius. (Refer to the following figure.)
- Adding excessive force may break the optical cable. Connect the optical cable so that it is not twisted, etc.



**Optical cables have a specified minimum cable bend radius. Falling under this limit may cause increase in loss and cable break. Also, twisting the optical cable may break it.**

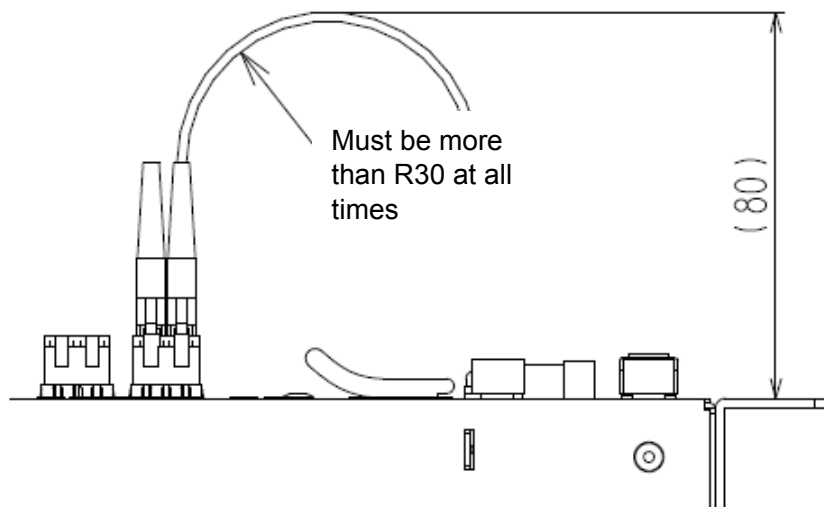

**Figure 2-17 How to Handle Optical Cables (When Using NEC-Recommended Cable)**

### 2.4.3 Insertion Procedures for Connectors

At shipment, this equipment has dust-proof caps on the coaxial cables. When inserting the coaxial cables, remove the dust-proof cap in advance.

<Connector on the cable inserted to this equipment>

DC Power Input Part (**DC-48V IN**): Connector (D-5200K(1-917807-2))

ASN-GW Connector (**ASN-GW**): RJ-45

GPS Antenna Terminal (**GPS ANT**): BNC connector

#### 2.4.3.1 Inserting Power Cable

Check that the breaker is OFF (On the **○** side) in advance. Insert the cable into the connector so that the surface with “1” printed on the connector of the cable is facing up.

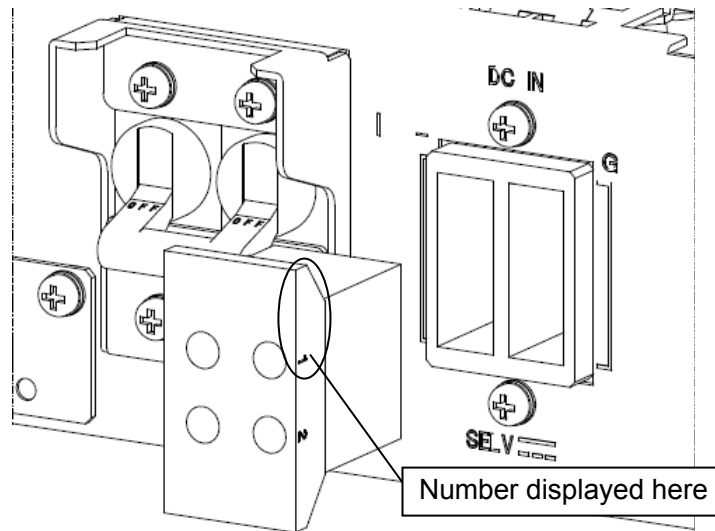
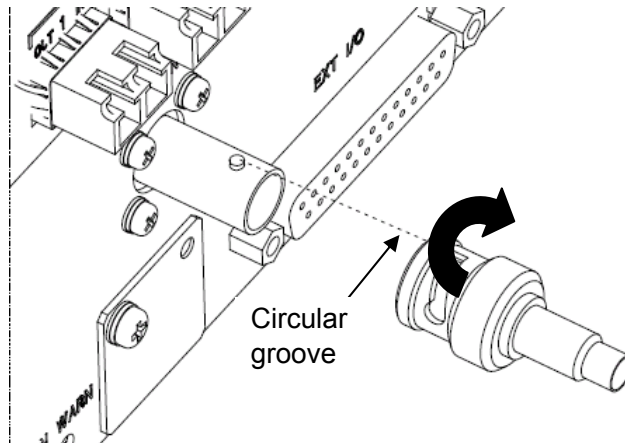

**Figure 2-18 Power Connection**



### 2.4.3.2 Inserting GPS-ANT Cable

Insert following the dotted line in the following figure. Then, rotate in the direction indicated by the arrow and fix the connector on the cable side. Check that the round projected part on the equipment side is firmly set in the circular groove.



**Figure 2-19 BNC Cable Connection**

Mount a surge protector for lightning protection.

Use an exclusive surge protector for GPS reception. (50Ω, DC+5V transparent)

The IDU supplies superimposed power to the GPS antenna.

Be sure to apply a prescribed grounding treatment to the Earth cable of the surge protector.

If there is a large attenuation from the GPS antenna to the IDU, add an exclusive inline amplifier for GPS antenna in order to ensure adequate gain for the connection to the IDU.

Install the GPS antenna referring to the following figure.

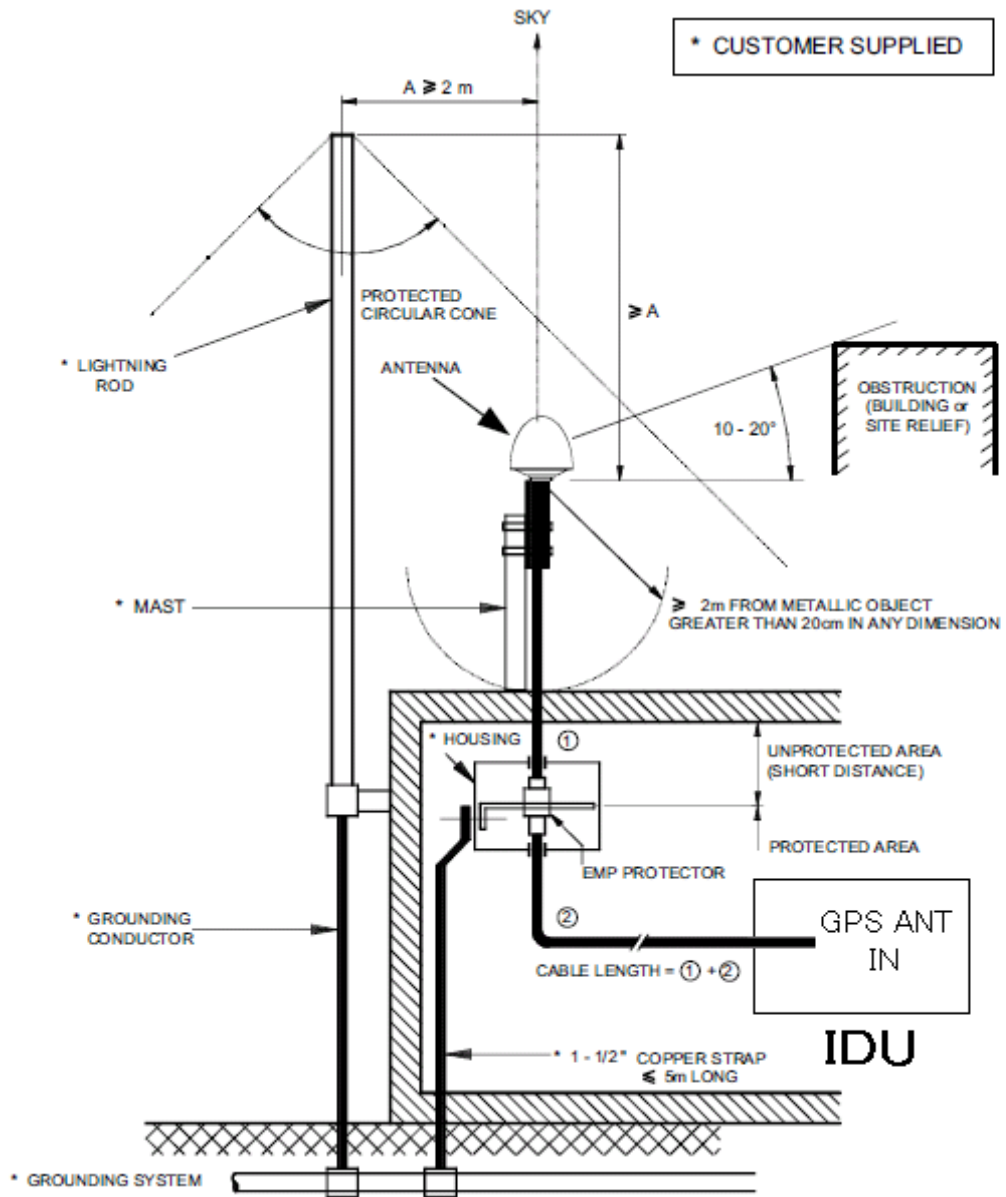
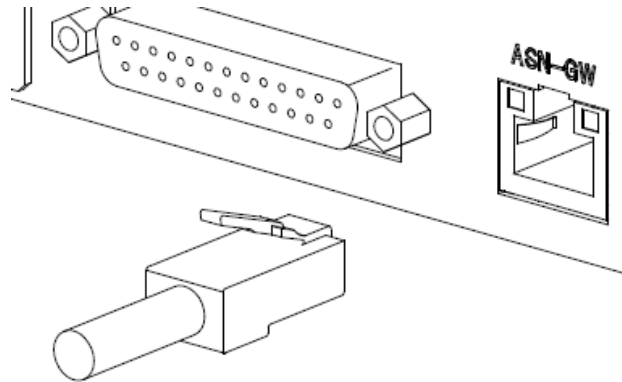

Figure 2-20 Installing GPS Antenna

- LAN Cable Connection

LAN cable is inserted into the **ASN-GW** connector on this equipment. Check that the LAN cable you prepared has LAN connector on the side inserted into this equipment and insert till you hear a click. Check that the cable is inserted and is not pulled off.



**Figure 2-21 LAN Cable Connection**

**2.4.3.3 Ground Connection**

Insert an Earth cable to the Ground connection terminal as function earth in left bottom part of front side IDU. Connect the other side of earth cable to a specified Ground point.

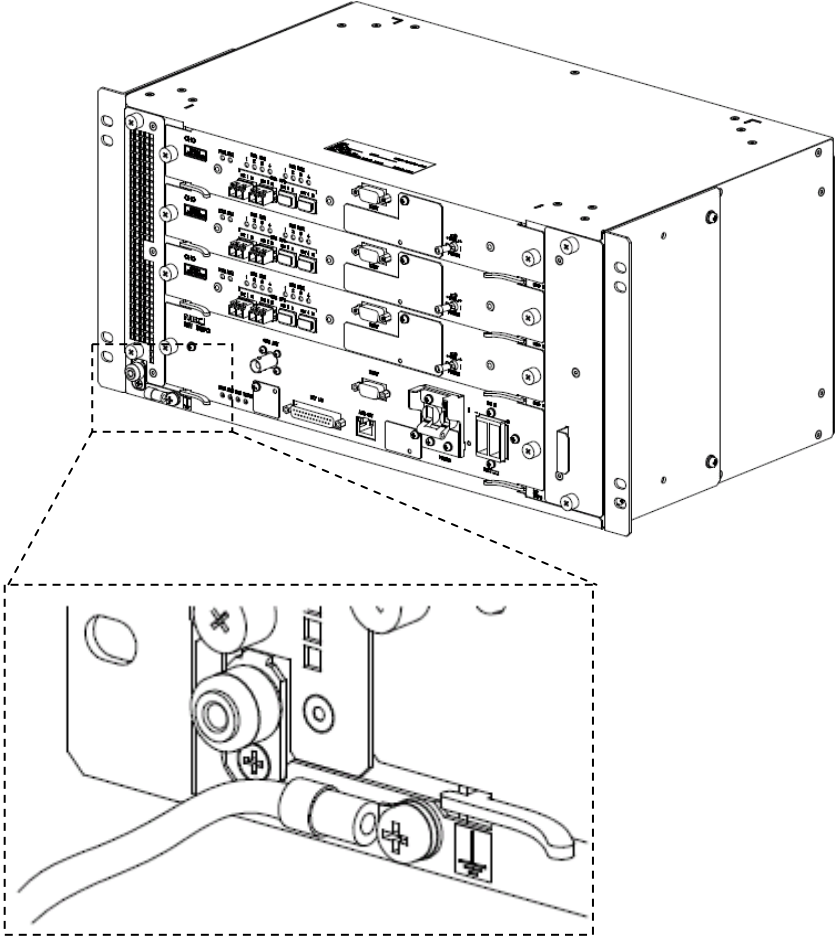

**Figure 2-22 Ground Connection**

**2.5 Power-On Procedures**

To turn on the power of the IDU and check its normal operation, follow Section 5. "BS Power-On" after completing the ODU installation and IDU-ODU cable connections.

**2.6 Technical Data**

**Table 2-7 Technical Data of IDU**

Model name	IDU NWA-024297
Power supply	DC-48V (Range: DC-38V to DC-57V)
Current Rating	8.3 A
Weight	16 kg
Temperature ranges	IDU: -5°C to +50°C
Humidity	90% *No condensation

### 3. ODU Installation

---

#### 3.1 Cautions upon Installation

- **CAUTION FOR ELECTRIC SHOCK:** this equipment is designed for use of DC-48V at outdoor environment pay attention for the risk of electric shock, because the contact resistance of the body is reduced when subjected to wet conditions.
- **CAUTION:** when working outdoors, stop the work while the weather is extreme with strong rain or wind. It may cause unexpected injuries.
- **CAUTION FOR LIGHTENING SURGE:** when lightening or thunder is occurring, do not work on installation of this equipment. You may be struck with lightening.
- This equipment is designed to place vertically. If you place horizontally, it may not function appropriately. Please make sure to place vertically with interface on the bottom.
- Do not place the equipment in vibrating or unstable area. Always fix the equipment in the place. The equipment may fall and cause injury otherwise.
- When carrying or moving the equipment, be careful not to drop to avoid unexpected accidents or injuries.
- When installing the equipment, be careful not to drop or misplace equipment parts, such as caps, tools, screws, brackets, etc to avoid unexpected accidents.
- Choose a place with enough strength to install the equipment. If a place does not have enough strength, the equipment may fall and cause unexpected accidents or injuries.
- Do not place metal pieces inside a connector. Pins may short-circuit which cause fire and breakage. Make sure to insert the connectors straight. Inserting the connectors in a slanted direction may cause the pins to short-circuit which cause fire and breakage.
- Never leave the connectors open on the equipment upon the installation. Cables must be inserted in each connectors. When a connector has to be left open, place the dust-proof caps on the connectors and waterproof it with self-welding tapes, etc. Note that dust-proof caps attached at shipment are not waterproof.
- Do not dismantle or alter this equipment. It may cause fire or electrical shocks.

3.2 ODU External View and Names

3.2.1 External View of ODU

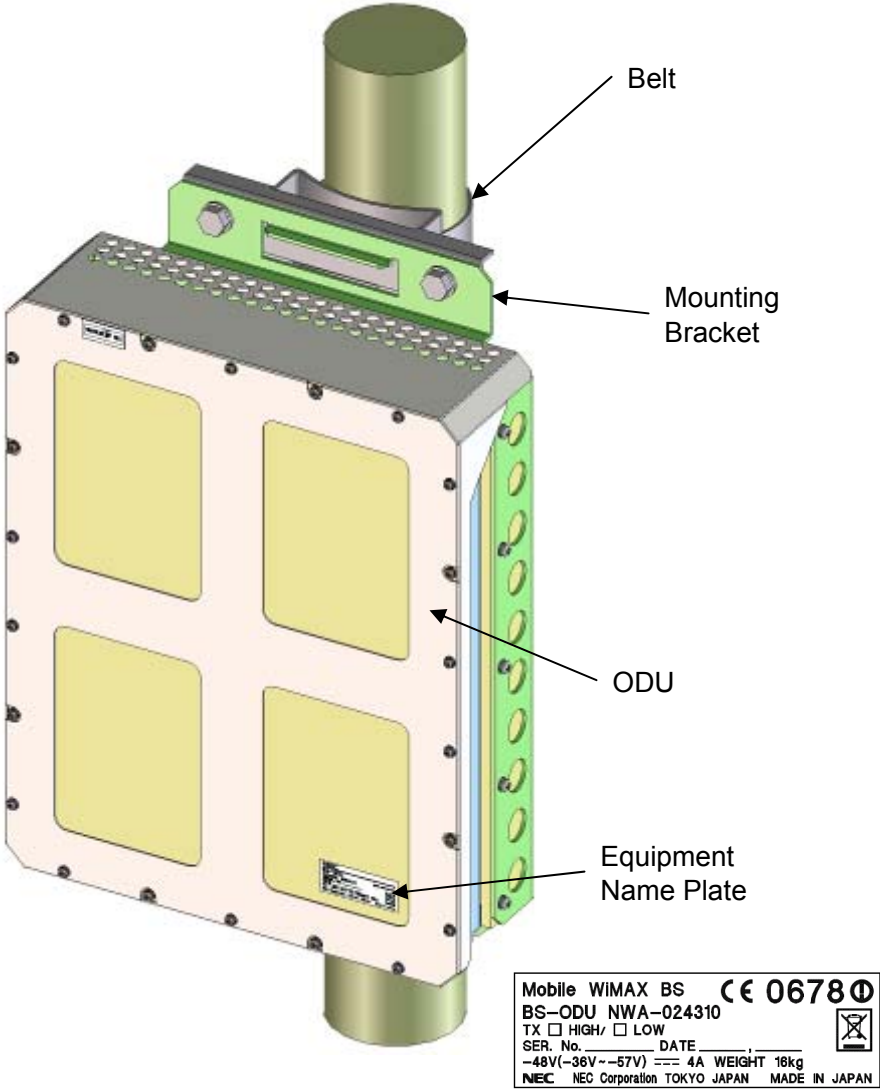

Figure 3-1 External View (3.5GHz ODU)

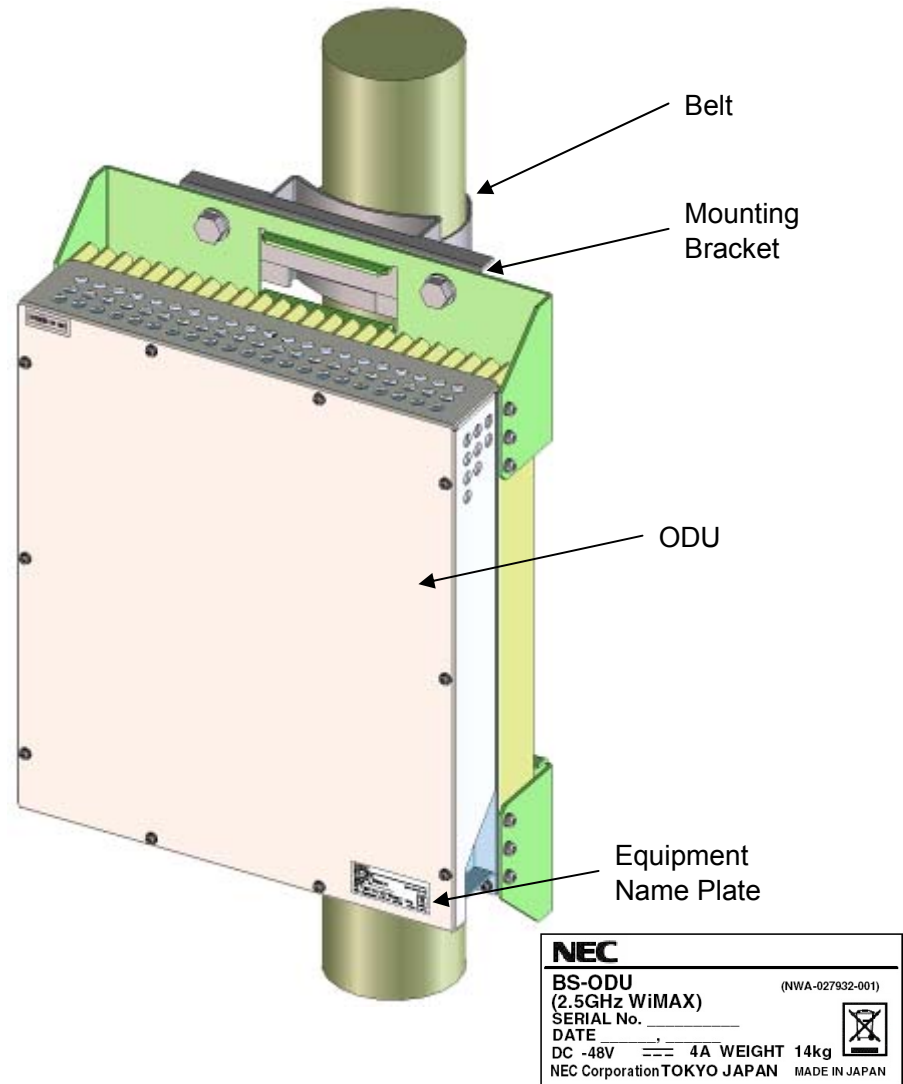

Figure 3-2 External View (2.5GHz ODU)



3.2.2 Dimensions and Interface Part Details

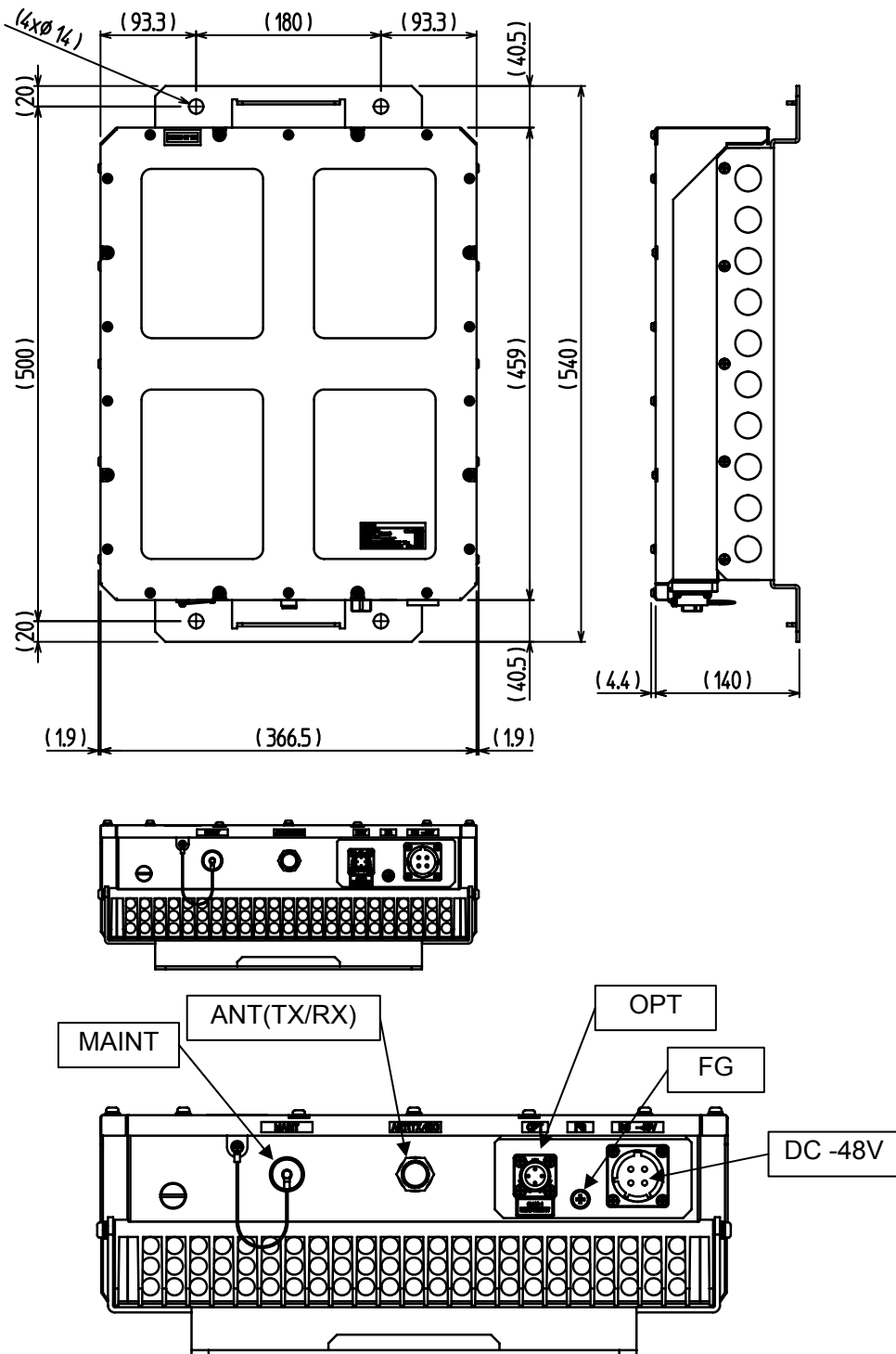

Figure 3-3 Dimensions of 3.5GHz ODU and Interface Part Details

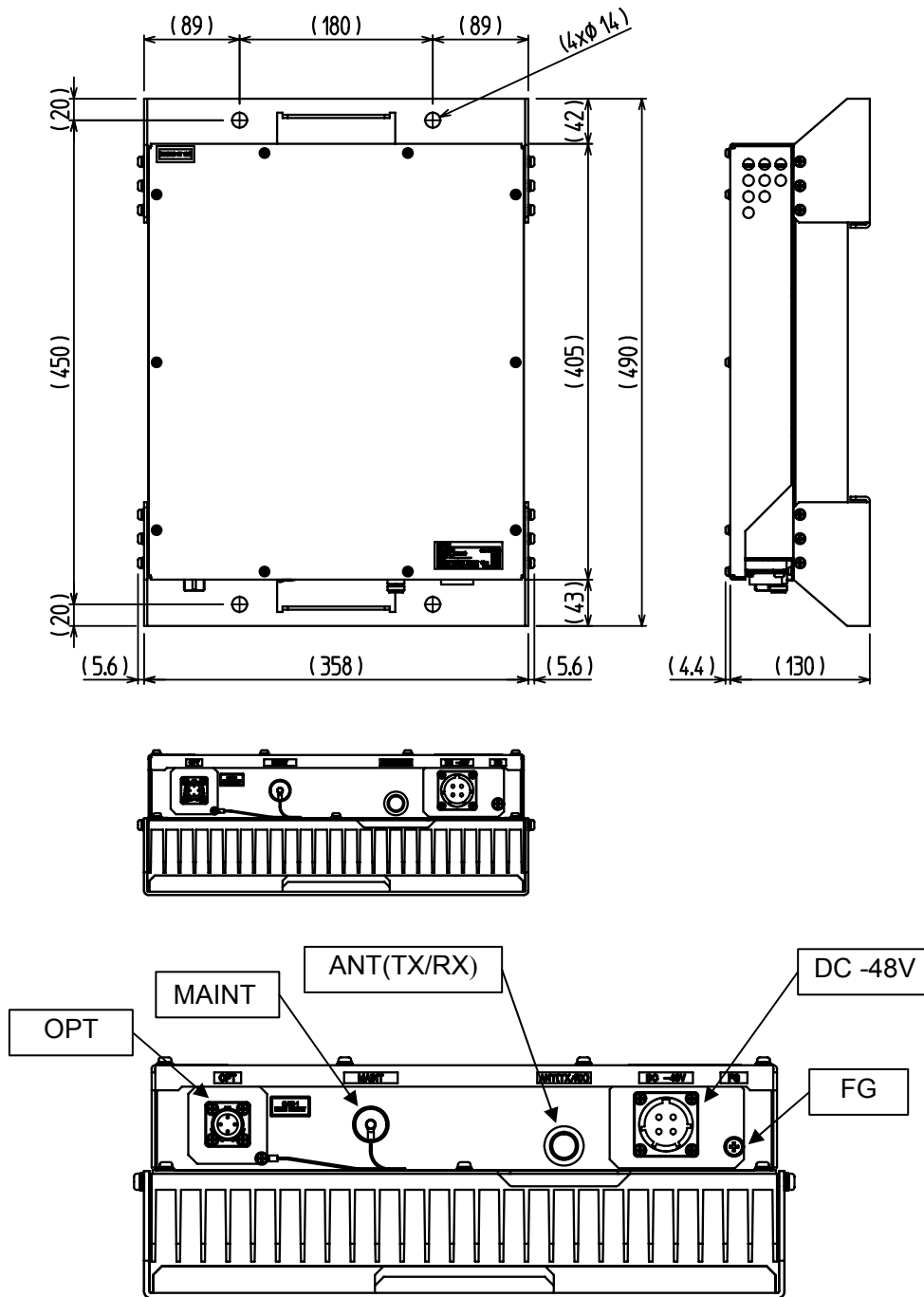

Figure 3-4 2.5GHz ODU Dimensions and Interface Part Details

### 3.3 Installation Procedures

#### 3.3.1 Carrying by Personnel

The following shows the cautions when carrying this equipment manually.

The maximum mass of ODU is 18kg. When carrying this equipment, always place your hands on the bottom surface. If parts other than the bottom surface are held, you may deform or break the equipment.



**When carrying this equipment, be careful not to hurt your hands with the projections, external connection cables, etc.**

#### 3.3.2 Places to Install This Equipment

This equipment can be installed to a pole or wall using the mounting hole. Here, the procedure to install this equipment on a pole is described.

#### 3.3.3 Used Tools, Materials and Tightening Torque

**Table 3-1 Used Tools and Materials**

Tools and Materials	Use	Quantity
Wrench with nominal diameter 19	For M12	1
Screw Driver	For M5	1
Self-welding tape	To waterproof cables	1
Silicon caulks (KE-45 manufactured by Shinetsu, etc.)	To prevent corrosion of FG part	1
Mounting Bracket manufactured by Iwabuchi (RABX)	To mount onto a pole	1
Belt (IBT-****)	To mount onto a pole	2

**Table 3-2 Tightening Torque**

Size	Tightening Torque {N – m}
M12	38±10%
M5	2.64

### 3.3.4 Mounting Procedure

When mounting this equipment on a pole, prepare a mounting bracket (RABX) for poles. The mounting procedure is common to 3.5GHz ODU and 2.5GHz ODU.

[Installation Procedure]

- 1 Attach the mounting brackets to the ODU and the pole.

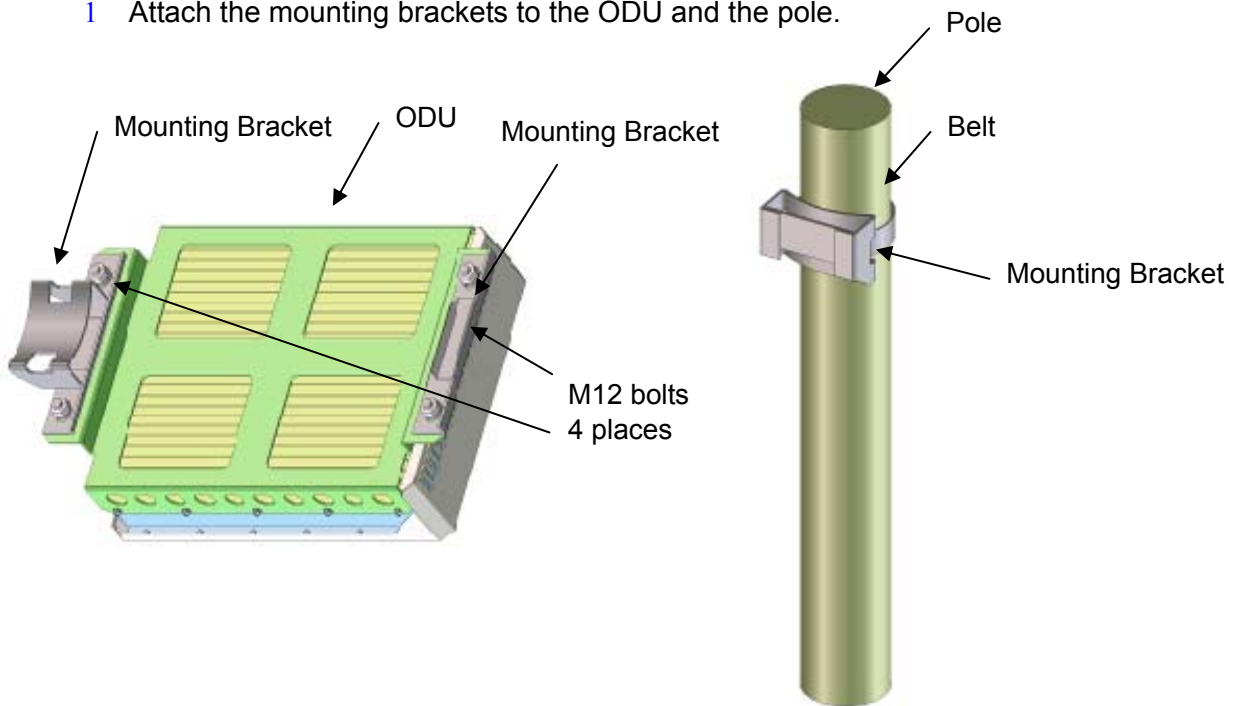

- 2 Hand the ODU to the mounting bracket on the pole, and fix the bottom mounting bracket with a belt.

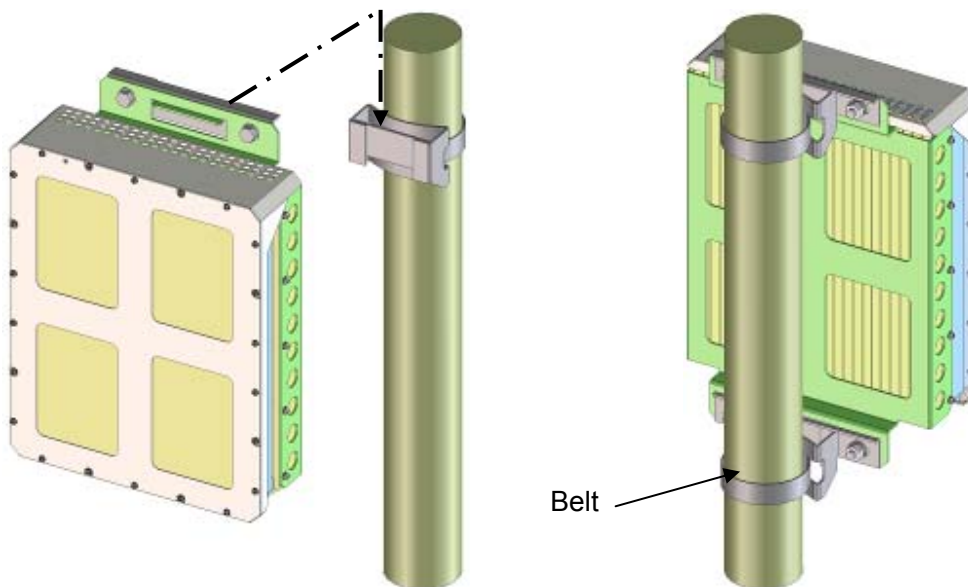

### 3.3.5 Removal Procedure

Remove the equipment by following the installation procedure from the end.



Equipment weighs 18kg, so when removing it hold the bottom surface firmly and be careful not to drop it.

## 3.4 External Connections

### 3.4.1 External Connection Terminals

The following describes the external connection terminals.

**Table 3-3 Power Input Terminal Connector**

No.	Items	Remarks	Q'ty
1	DC Power Terminal Connector DC-48V IN	On the equipment side: JR25WR-4P by Hirose	1
		On the cable side : JR25WP-4S by Hirose	1

**Table 3-4 Always-Connected Connectors**

No.	Items	Remarks	Q'ty
1	Optical Connector OPT	On the equipment side: FOJ-FSP-RA-001 by DDK	1
		On the cable side : FOJ-FSP-PA-001 by DDK	1

### 3.4.2 Insertion Procedures of Connectors

At shipment, this equipment has dust-proof caps on the cables. When inserting the cables, remove the dust-proof cap in advance.



Dust-proof caps are not waterproof. When using this equipment outdoors, always perform the specified cable connections and installations.

<Connector on the cable inserted to this equipment>

DC Power Input Part (DC-48V IN): Connector (NEC specified type)

FG Connection Part (FG) : Circular terminal for M5

Antenna terminal (ANT(TX/RX)): N connector

~ IDU connection (OPT) : Connector (NEC specified type)

### 3.4.2.1 Power Cable Insertion Procedure

Check that the power supply breaker is OFF. Insert the cable so that the connector fits the groove on the connector shell, and rotate the outer circumference of the connector shell firmly to tighten it.

To ensure waterproofing, roll up a self-welding tape on the connecting part. (See 3.4.2.6.)

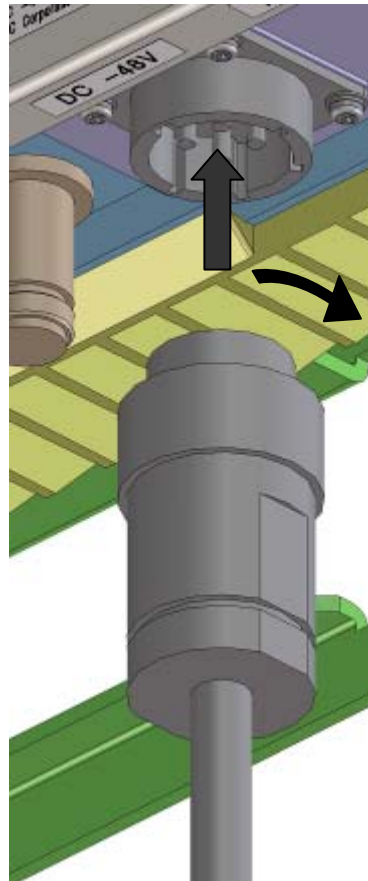
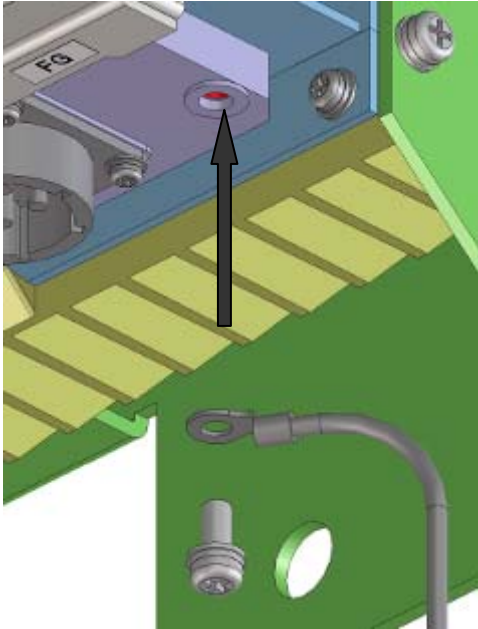

**Figure 3-5 Power Cable Connection**

**3.4.2.2 FG Cable Insertion Procedure**

---

- 1 Remove the M5 screw and install the circular terminal for M5.



- 2 Replace the M5 screw, then apply the silicon caulks around the M5 screw.

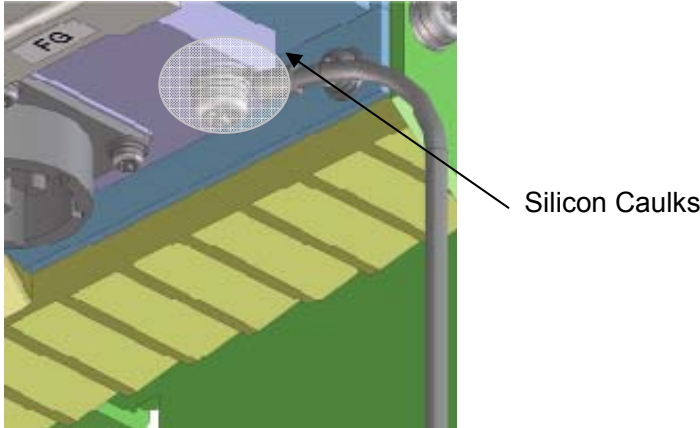
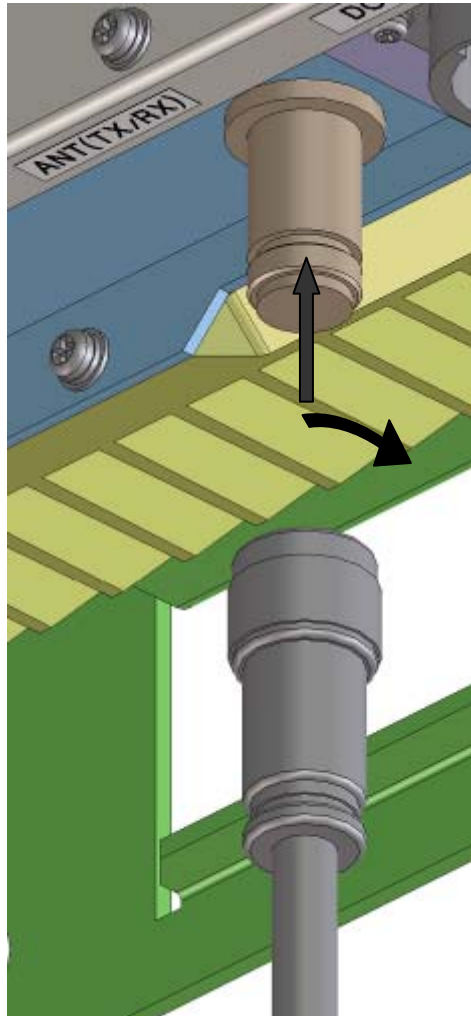

**Figure 3-6 FG Cable Part Corrosion Prevention**

### 3.4.2.3 Antenna Terminal Cable Insertion Procedure

Check that the breaker at the power supply is OFF. Insert the connector shell, and rotate the outer circumference of the shell to tighten it.

To ensure waterproofing, roll up a self-welding tape on the connecting part. (See 3.4.2.6.)



**Figure 3-7 Cable Connection to Antenna Terminal**



As a lightning surge measure, connect the arrester to the connecting part of the antenna port.



**Figure 3-8 Arrester for thunder surge measure (N-SA-JP-C1)**

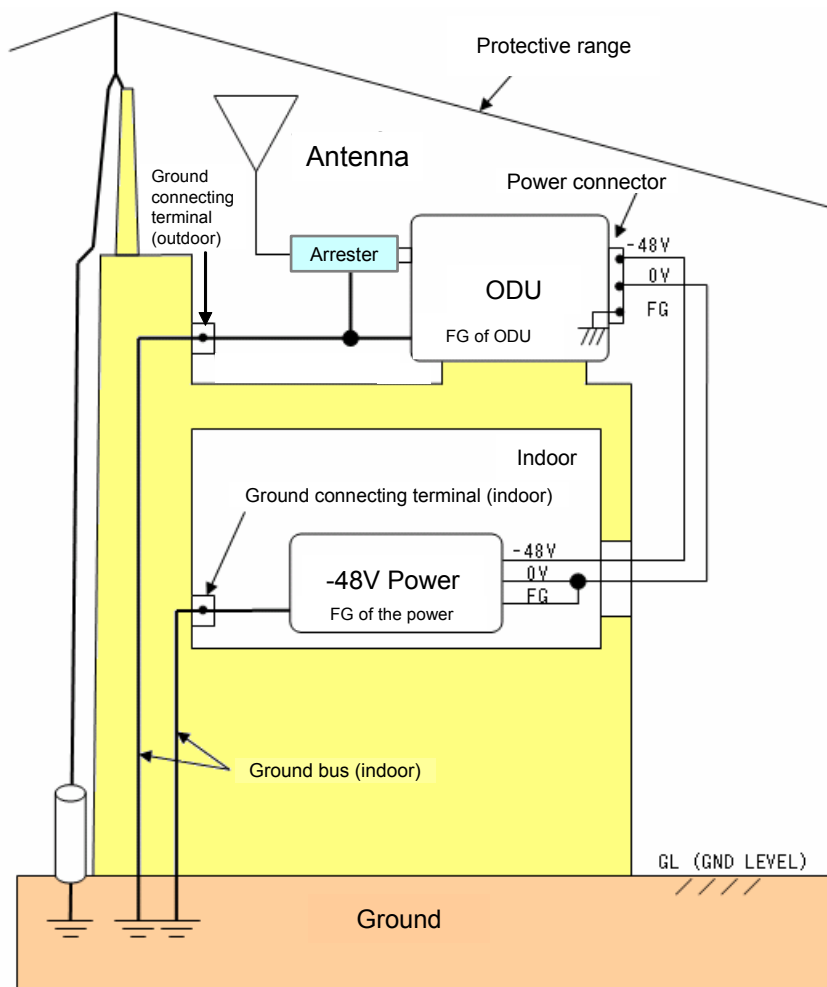
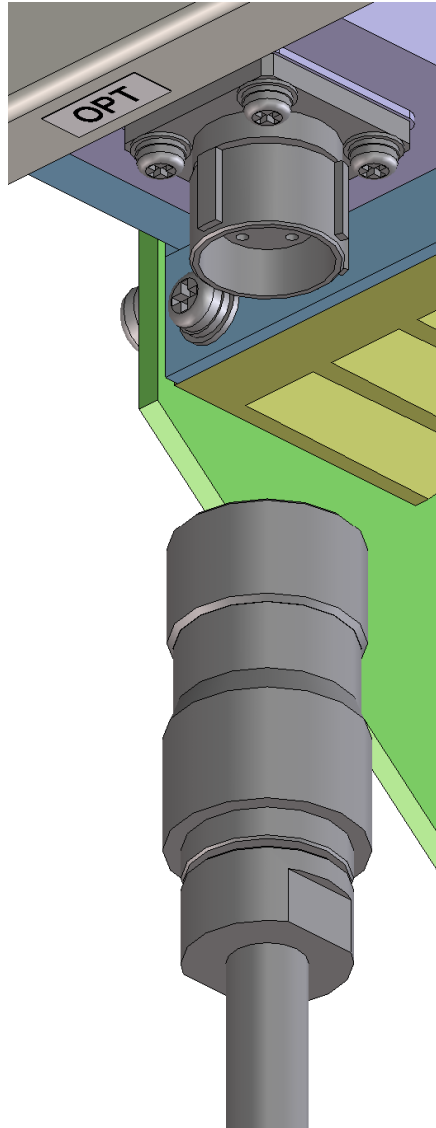

**Figure 3-9 Arrester Placement Position**

### 3.4.2.4 Optical Cable Insertion Procedure

OPT connector on the ODU equipment is a special outdoor connector for this equipment. Check that the optical cable you prepared is for this equipment. Insert the optical cable till you hear a click.

To ensure waterproofing, roll up a self-welding tape on the connecting part. (See 3.4.2.6.)



**Figure 3-10 Optical Connector Insertion/Removal Details**

### 3.4.2.5 Cautions on Handling Optical Cables

- For the optical cables to connect to **OPT** connectors of this equipment, leave surplus length so that the bend radius is not below the specified minimum cable bend radius. (Minimum cable bend radius: 200mm)
- Adding excessive force may break the optical cable. Connect the optical cable so that it is not twisted, etc.
- When excessive force is applied to the **OPT** connector part, the waterproof function of the connector may become impaired. When forming optical cable, be careful not to apply load on the connector.



**Optical cables have a specified minimum cable bend radius. Falling under this limit may cause increase in loss and cable break. Also, twisting the optical cable may break it.**

### 3.4.2.6 Waterproofing with Self-welding Tapes

Roll up a waterproofing self-welding tape on each connector. The rolling up of the layers should be done by overlapping the preceding one of half. (To secure waterproofing, be sure to firmly roll the tap up to the root of the connector.)

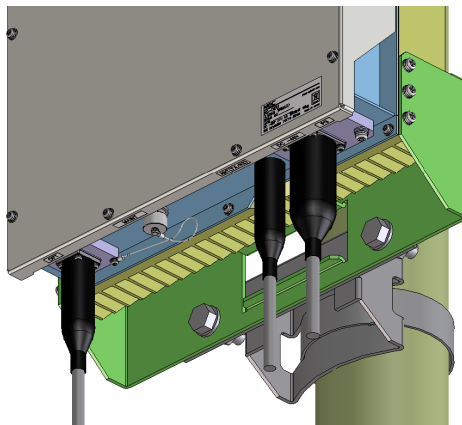

**2.5GHz ODU**

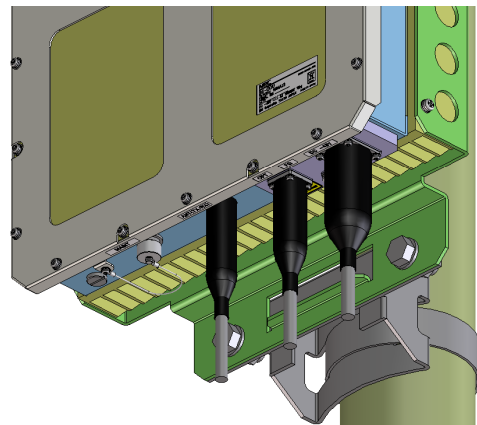

**3,5GHz ODU**

**Figure 3-11 Waterproofing Connectors**

### 3.5 Technical Data

**Table 3-5 Technical Data of ODU**

Model Name	3.5GHz ODU: BS-ODU NWA-024310 2.5GHz ODU: BS-ODU NWA-027932
Power supply	DC-48V (Range: DC-36V to DC-57V)
Current Rating	3.5GHz ODU: 4A 2.5GHz ODU: 4A
IP Protection code	IP66
Weight	3.5GHz ODU: 16 kg 2.5GHz ODU: 14 kg
Frequency Range	3.5GHz ODU: 3400 MHz to 3600 MHz 2.5GHz ODU: 2496 MHz to 2690 MHz
Maximum output power	+38dBm (3.5G), +40dBm (2.5G)
Radio access system	SOFDMA
Modulation method	QPSK, 16QAM, and 64QAM(*) * 64QAM is supported for DL only.
Complex communication system	TDD
Temperature ranges	-33°C to +50°C
Humidity	90% *No condensation

## 4. BS Connection Diagrams

The following figure shows the cable connection diagram of BS equipment.

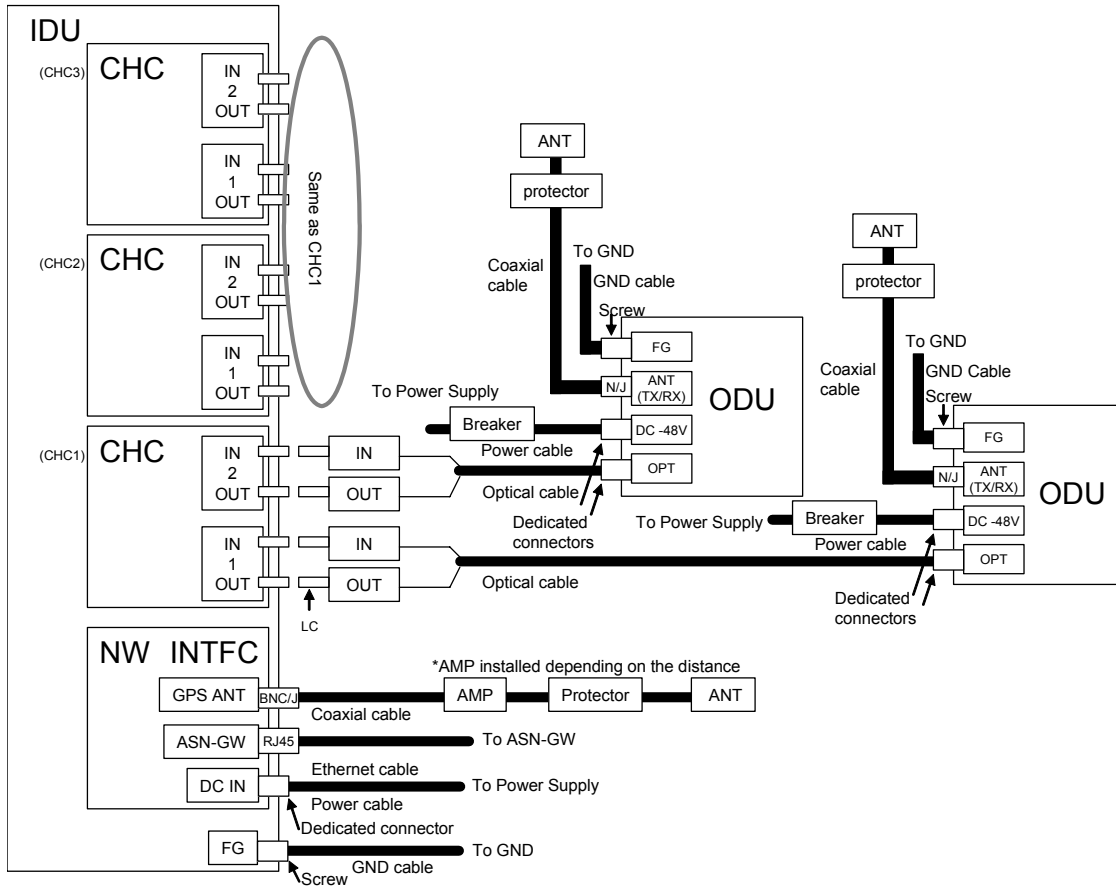

**Figure 4-1 Cable Connection Diagram**

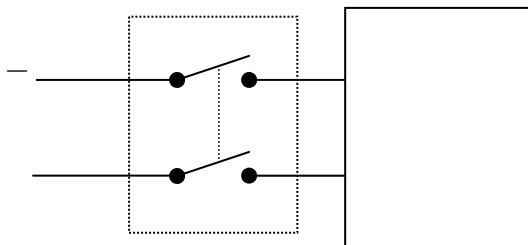

**Figure 4-2 Breaker Details**

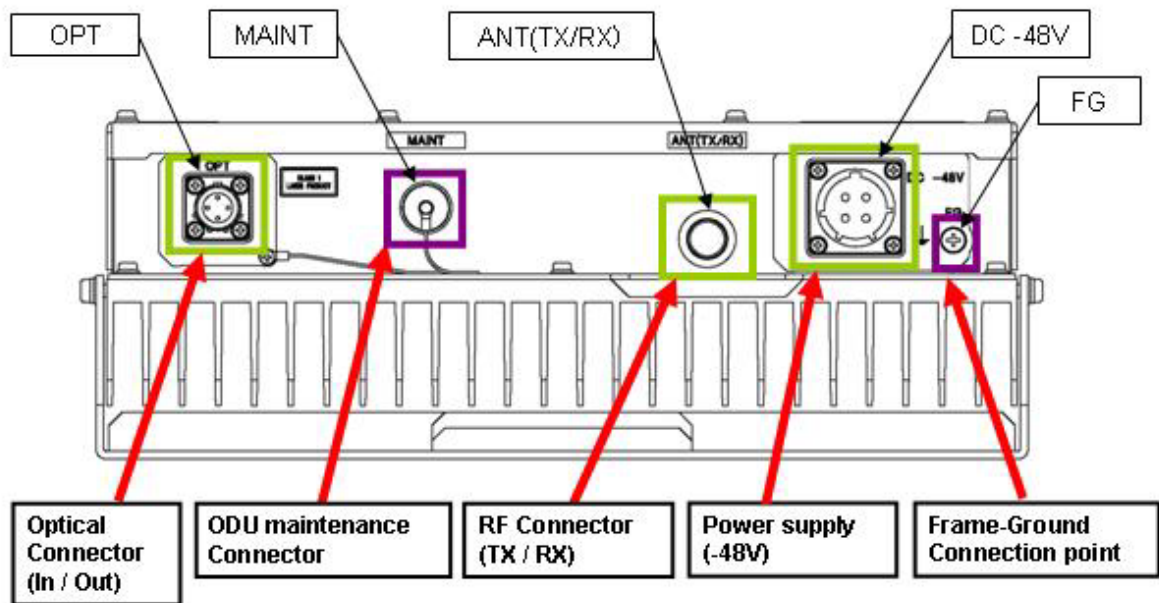

Figure 4-3 2.5GHz ODU connector

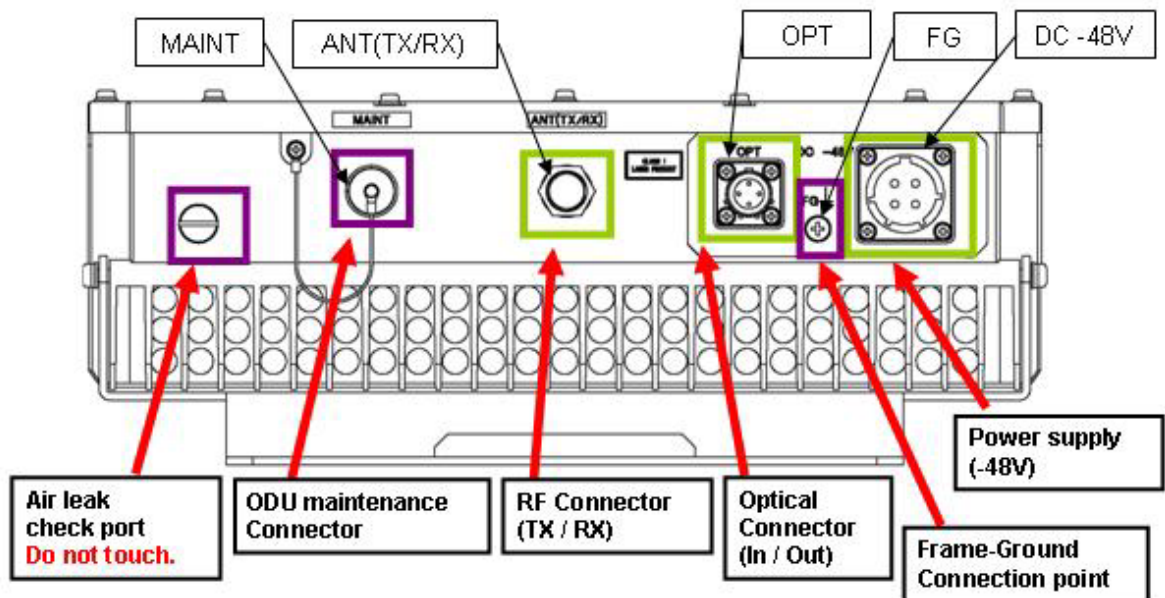
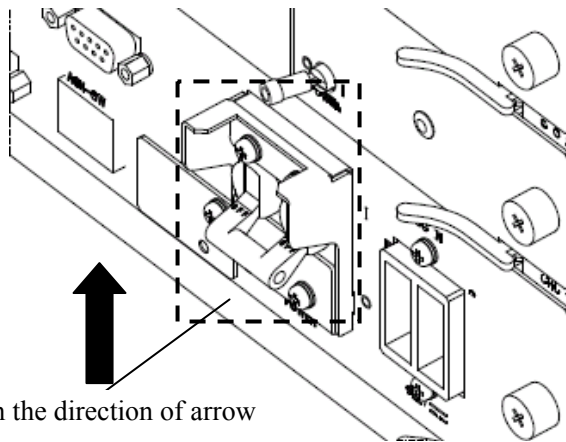

Figure 4-4 3.5GHz ODU connector

## 5. BS Power-On

Power-on the BS as follows:

- 1 Before turning the main power circuit breaker (MAIN) on the NW INTFC of the IDU ON, check that all toggle switches on CHCs are OFF (O side).
- 2 Turn on the breaker for the ODU. (There is no power switch on the ODU.)
- 3 Turn on the main power circuit breaker POWER on NW INTFC of the IDU. PWR LED on the front of NW INTFC lights in green.



Push up the breaker in the direction of arrow

- 1 At this time, FAN UNIT operates. FAN LED on the front of NW INTFC does not light. (FAN LED, used as FAN ALM, lights only when a fan alarm occurs.)
- 2 Also, the GPS receiver operates, with WARN LED lighted. WARN LED goes out upon completion of GPS synchronization.
- 3 Switch on the CHC1 toggle switch (pull it and set it from O to I). PWR LED on the front of CHC1 lights in green.

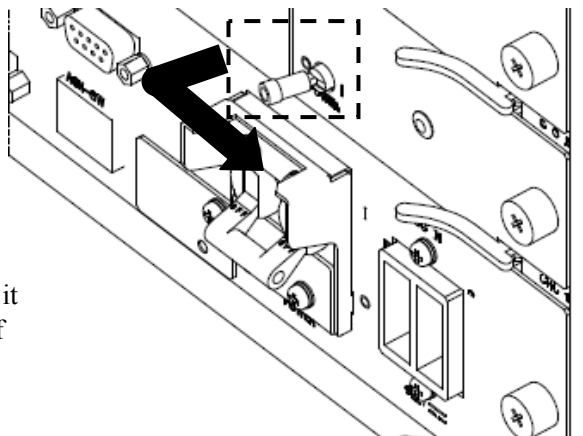

Pull towards yourself and fold it in the direction of arrow

- 4 Switch on the CHC2 toggle switch (pull it and set it from **O** to **I**). PWR LED on the front of CHC2 lights in green.
- 5 Switch on the CHC3 toggle switch (pull it and set it from **O** to **I**). PWR LED on the front of CHC3 lights in green.

You can carry out steps to turn on the CHC1 to CHC3 in any order.



## CAUTIONS

After turning the GPS (MAIN on the NW INTFC of the IDU) power on, it takes time to capture the satellite and the accuracy level reaches the acceptable range for normal operation.

Use it after WARN LED goes out.

The time until the accuracy level reaches the acceptable range is influenced by the surrounding environment of the GPS satellite and the GPS antenna location. Even in ideal condition (the whole sky is visible and more than four satellites can be captured at the same time), it takes approximately 15 minutes.



## 6. Appendix - Samples of Installation Layouts and Materials

---

### 6.1 Site Layout

Various equipment installation positions exist, depending on the different site conditions. The following indicates the typical installation positions.

In this section, layout examples of the equipment constructing the site are introduced. For details on mounting antenna poles, ODU and IDU, refer to sections 6.6 to 6.8 .

(1) Type-1: Installing equipment on H Beams

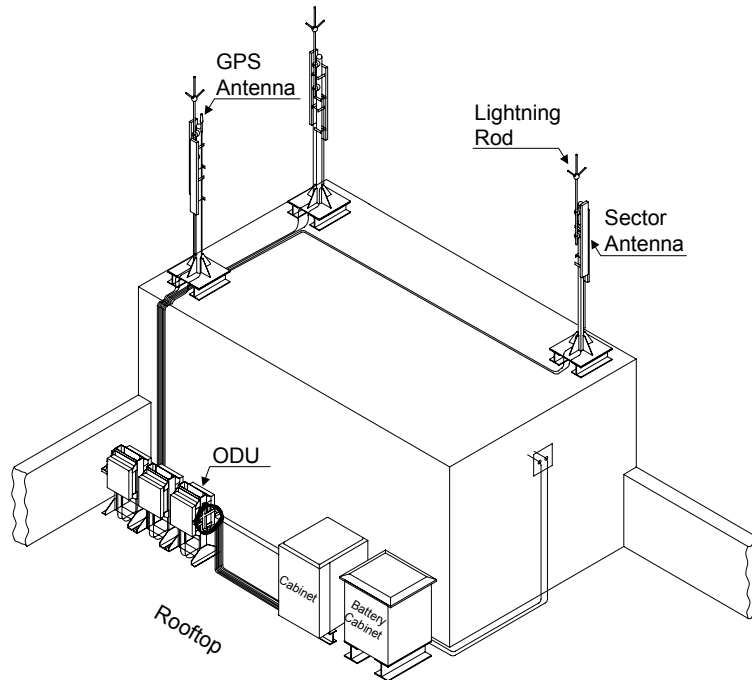

(2) Type-2: Installing equipment on concrete foundations

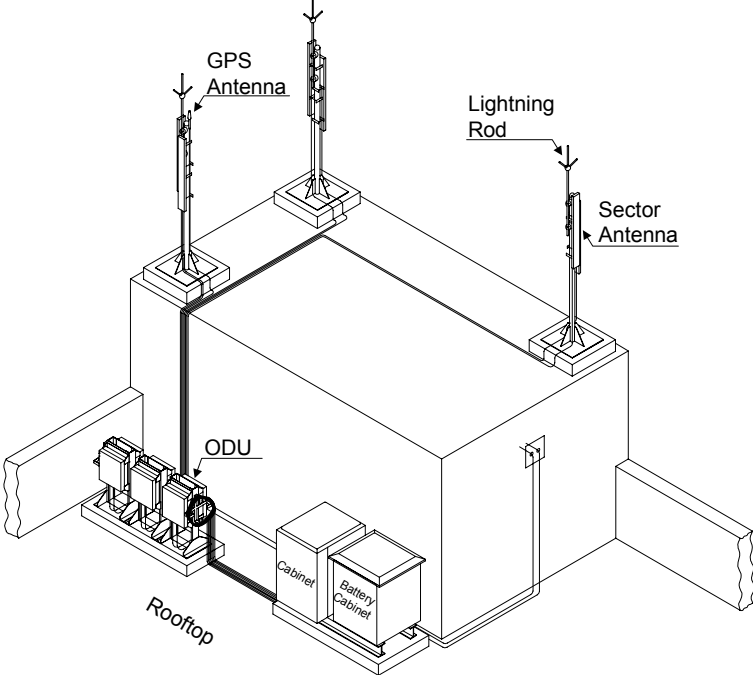

(3) Type-3: Installing ODU on antenna poles

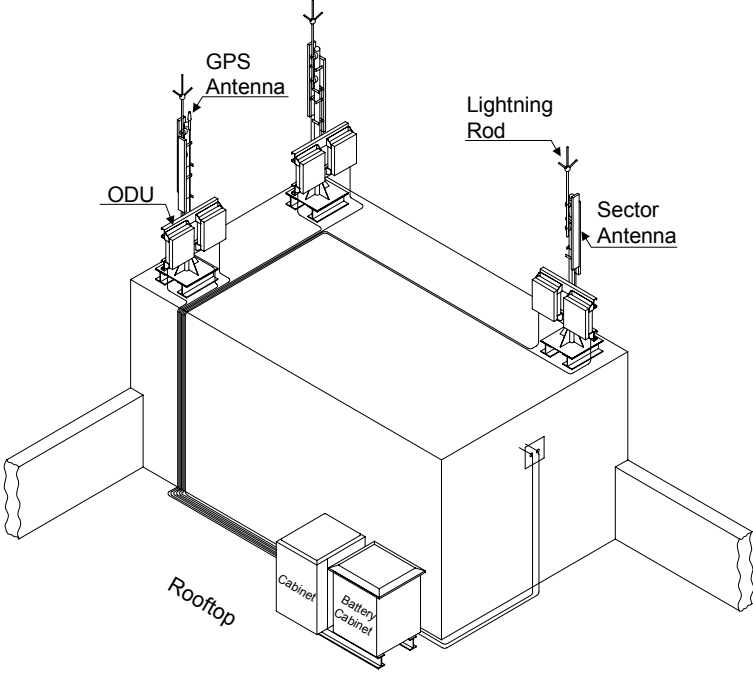

(4) Type-4: Installing ODU on a wall surface

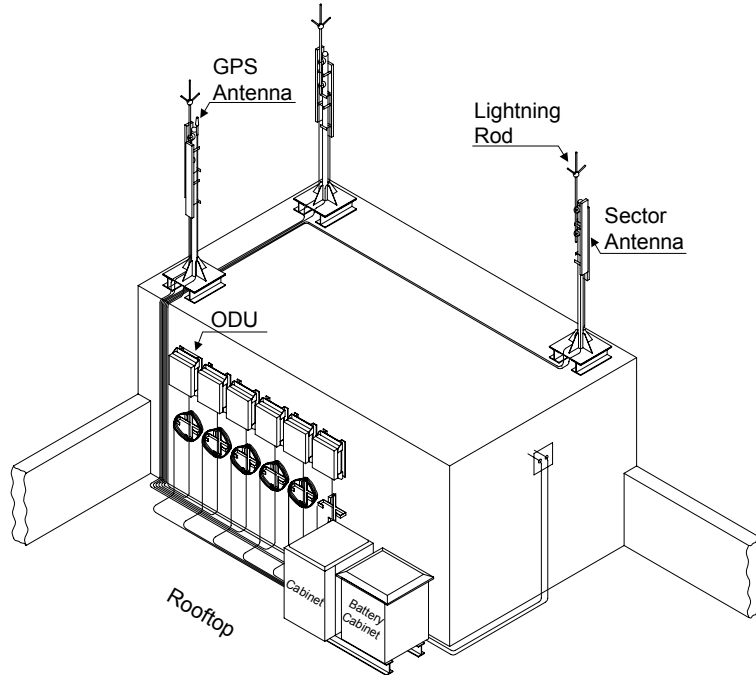

(5) Type-5: Installing all equipment on the rooftop of a building

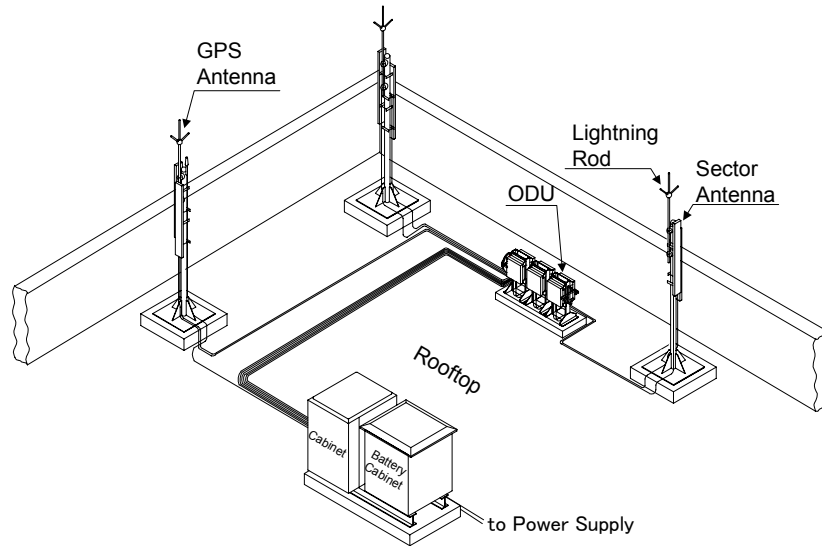

(6) Type-6: Installing an antenna on a wall surface

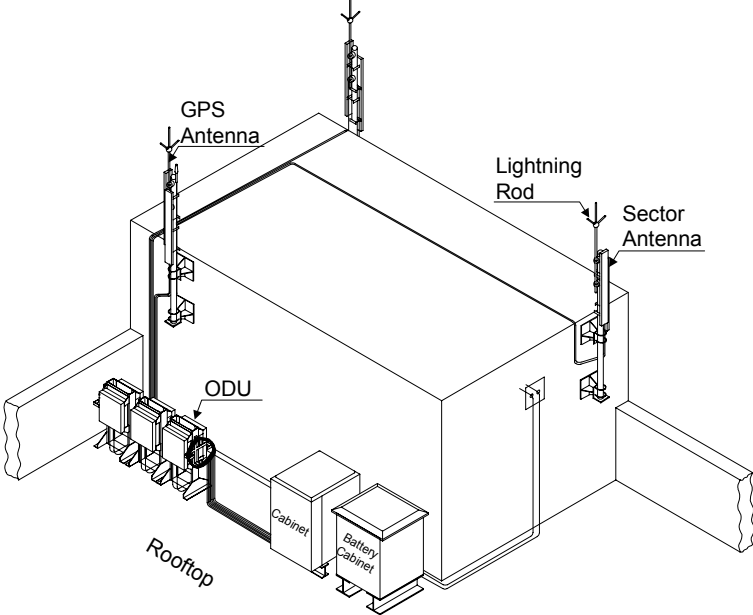

(7) Type-7: Installing antenna on tower

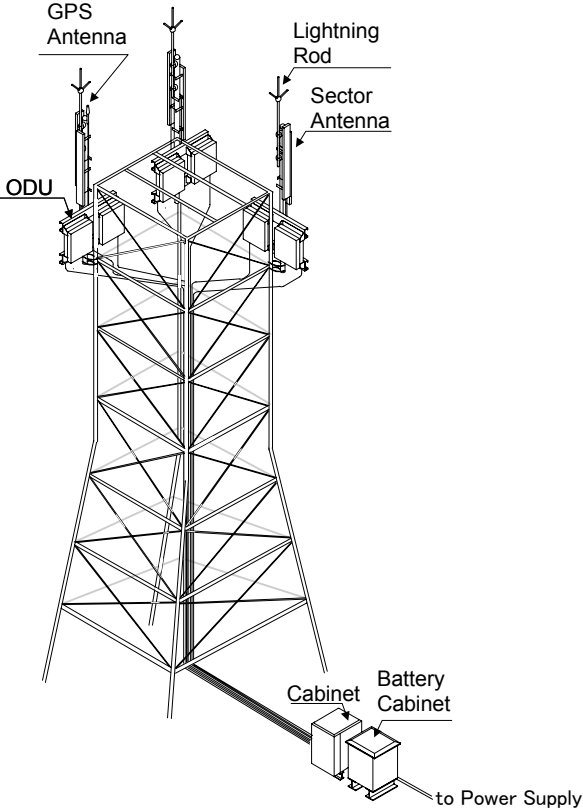

## 6.2 Floor Layout

The following indicates a recommended floor layout example for Type-1/ Type-2.

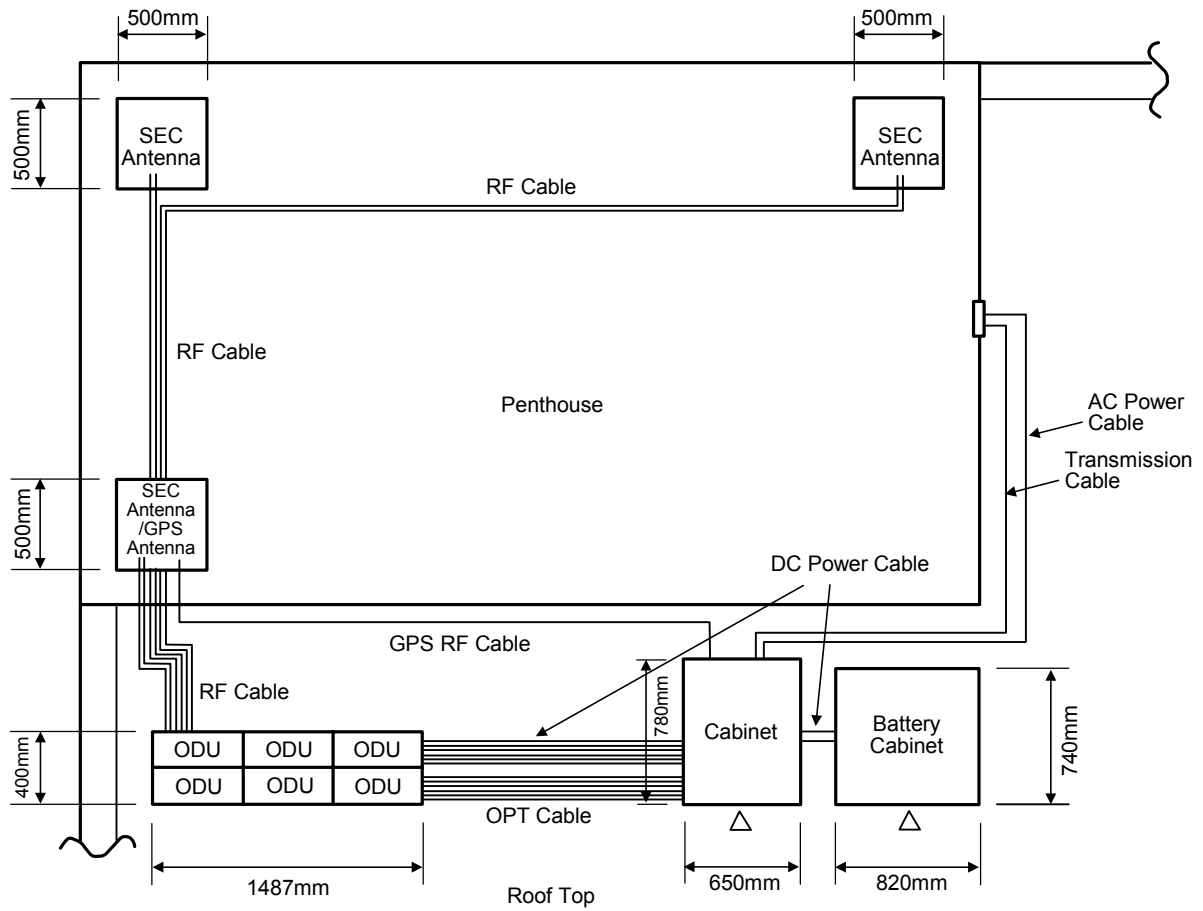

### **6.3 Power Wiring Diagram**

The following indicates the power wiring diagram between the equipment at the site.

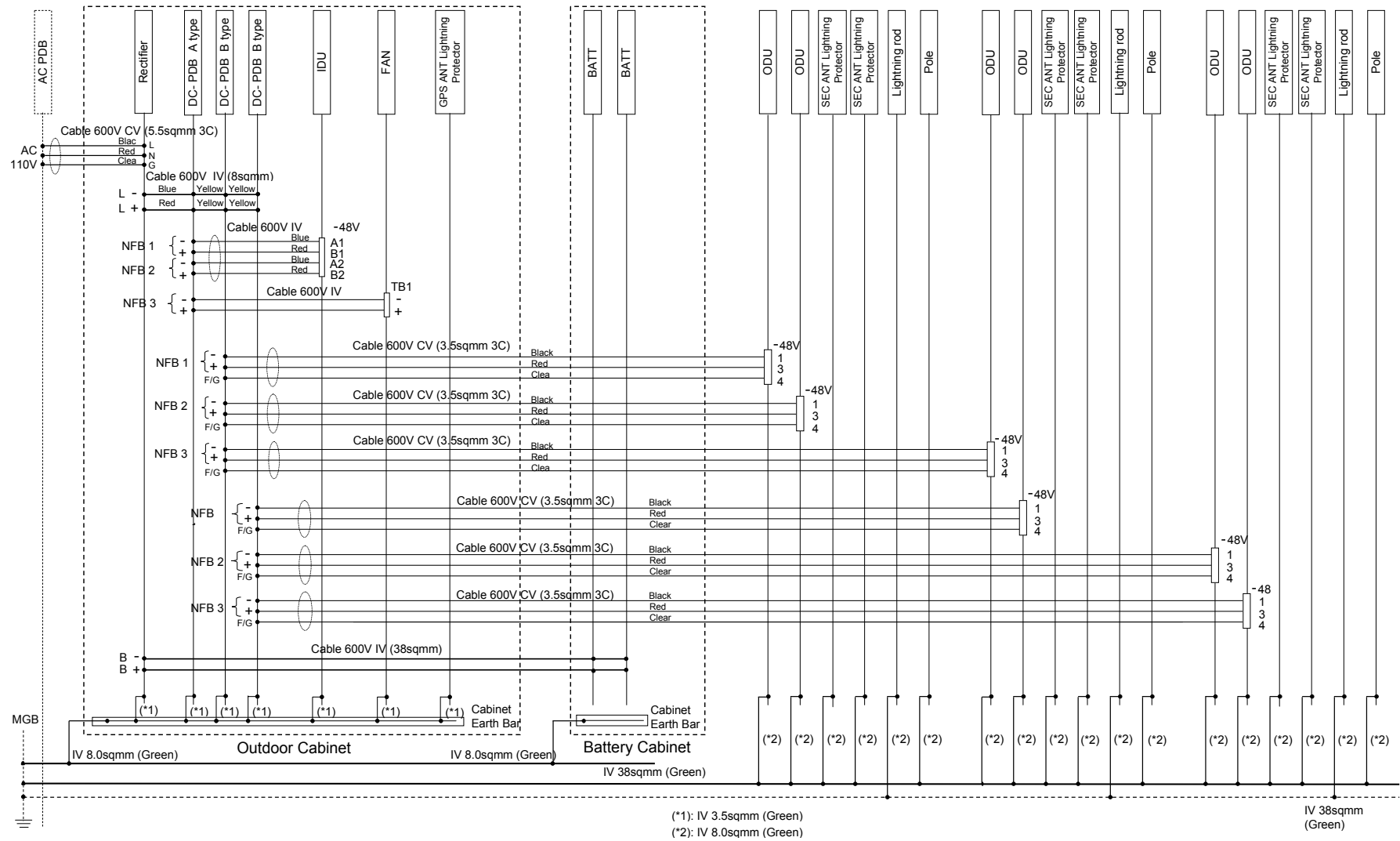

## 6.4 Signal Wiring Diagram

The following indicates the signal wiring diagram between the equipment at the site.

<b>Cable Type</b>	<b>Used for</b>
GbEther Cable	Connection between ASN-GW - NW INTFC
5D-SFA Cable	Connection between NW INTF - GPA ANT
8D-SFA Cable	Connection between ODU - SEC ANT
12D-SFA Cable	Connection between NW INTF - GPA ANT (when the distance between GPS and IDU is more than 15m) Connection between ODU - SEC ANT (when the cable length is 14m or more)
OPT INTF Cable	Connection between CHC - ODU



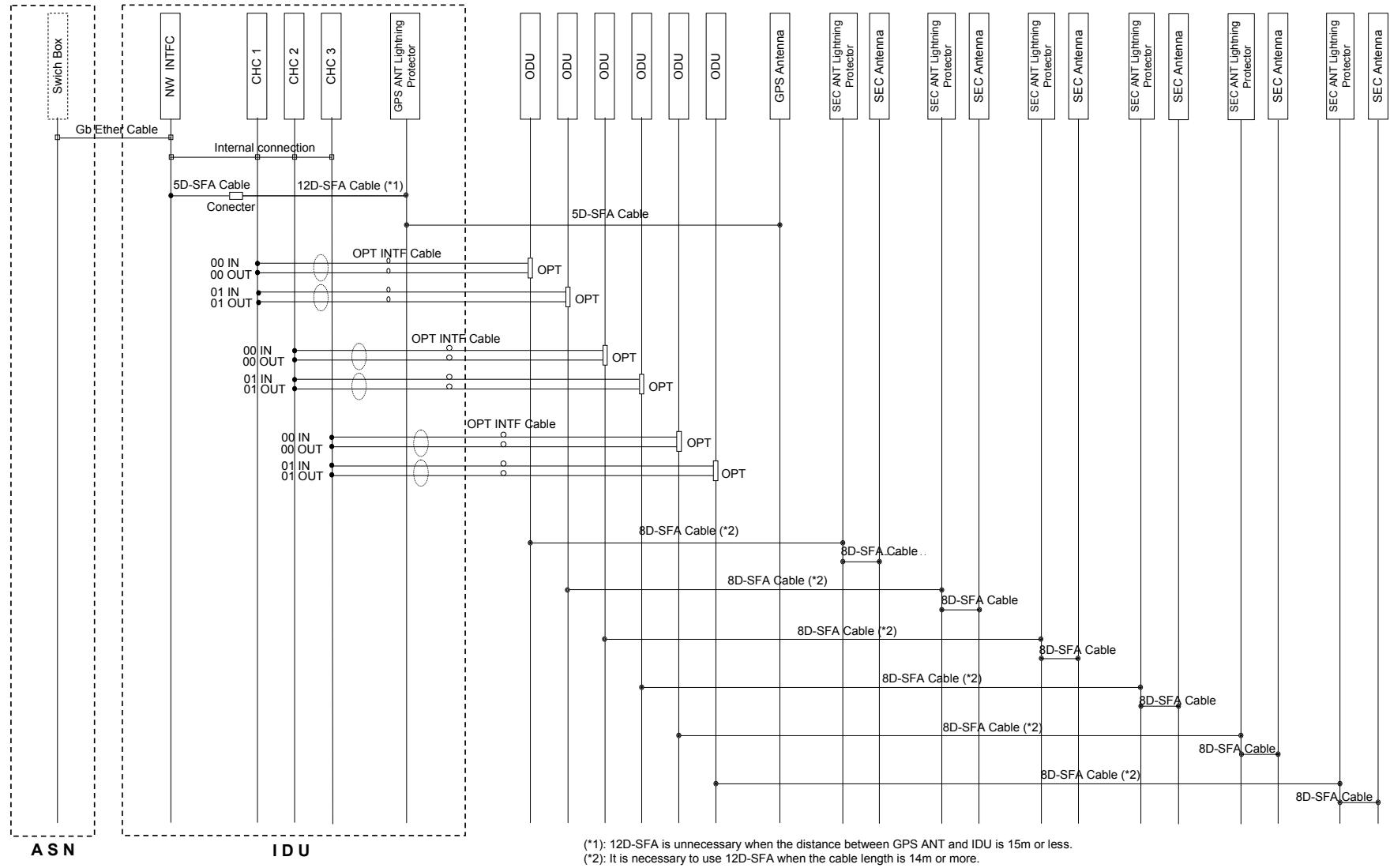

### 6.5 Bayface Layout

The following indicates the bayface layout in case a 20U standard rack is used. Reserve the 5U in the middle shelves for IDU.

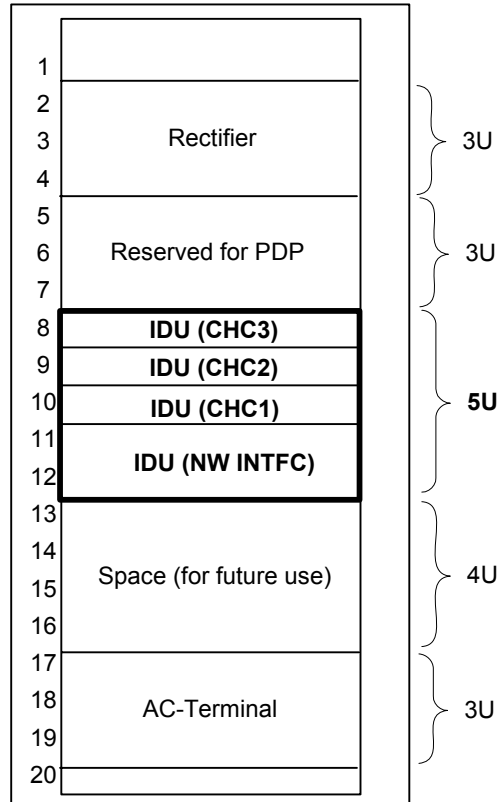

### 6.6 Antenna Pole Samples

The following indicates the antenna pole installation method examples.

#### (1) Roof Top Antenna Type

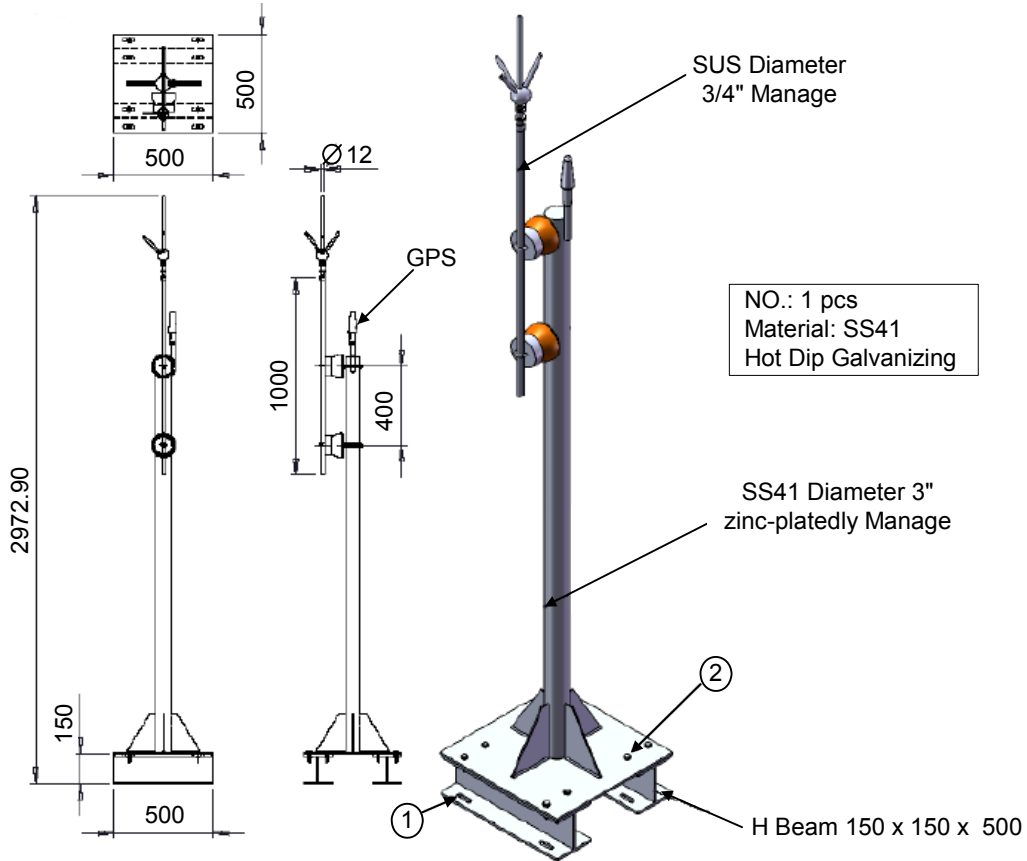

This item weighs 55 kg. (Excluding GPS and Lightning rod)

NO.	Materials
1	Bearing of ground SUS 1/2" x 3.5"L - 8pcs, Expansion bolt.
2	Hot Dip Galvanizing M12 x 1.75P x 50 - 8pcs.

(2) Antenna on Foundation Type

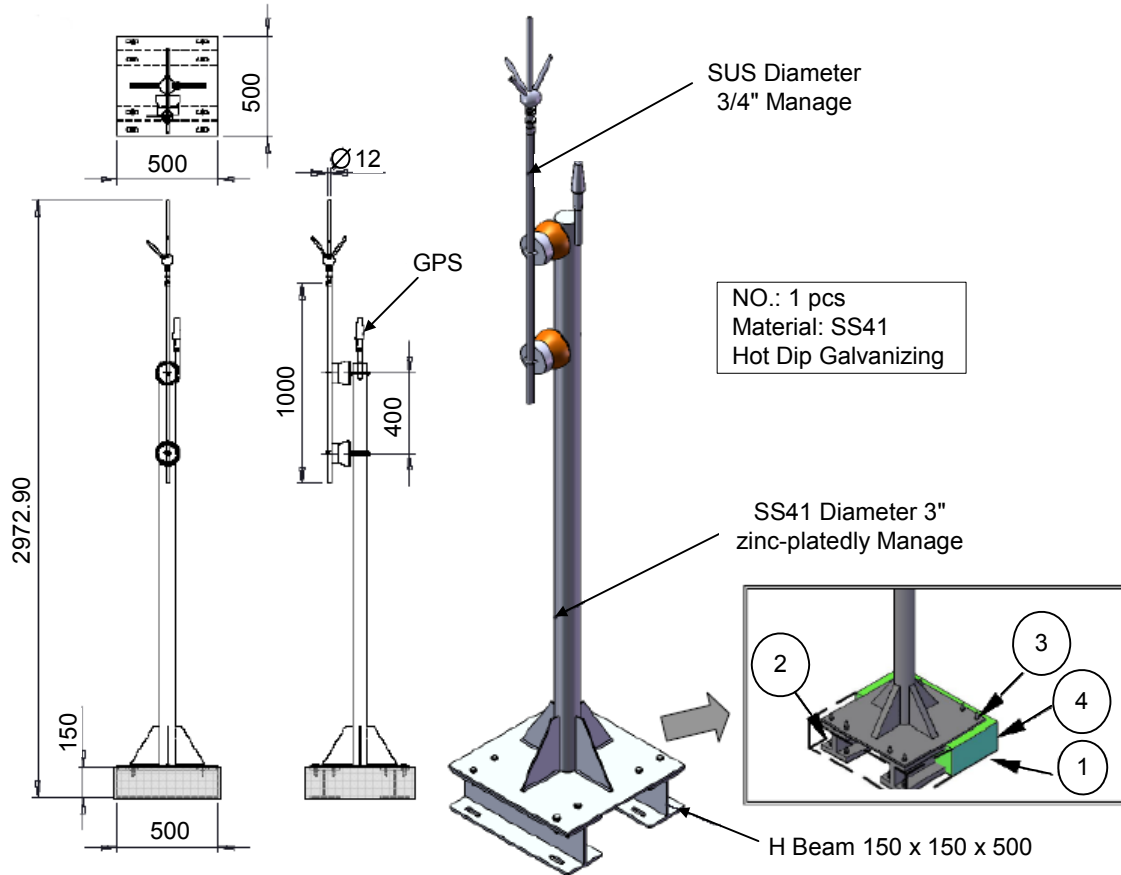

This item weighs 55 kg. (Excluding GPS and Lightning rod)

NO.	Materials
1	Foundation: L70 cm x W70 cm x H15 cm.
2	SUS 1/2" x 3.5"L - 8pcs, Expansion bolt.
3	Hot Dip Galvanizing M12 x 1.75P x 50L - 8pcs.
4	Waterproof paint of PU elasticity.

(3) Wall Mount Type

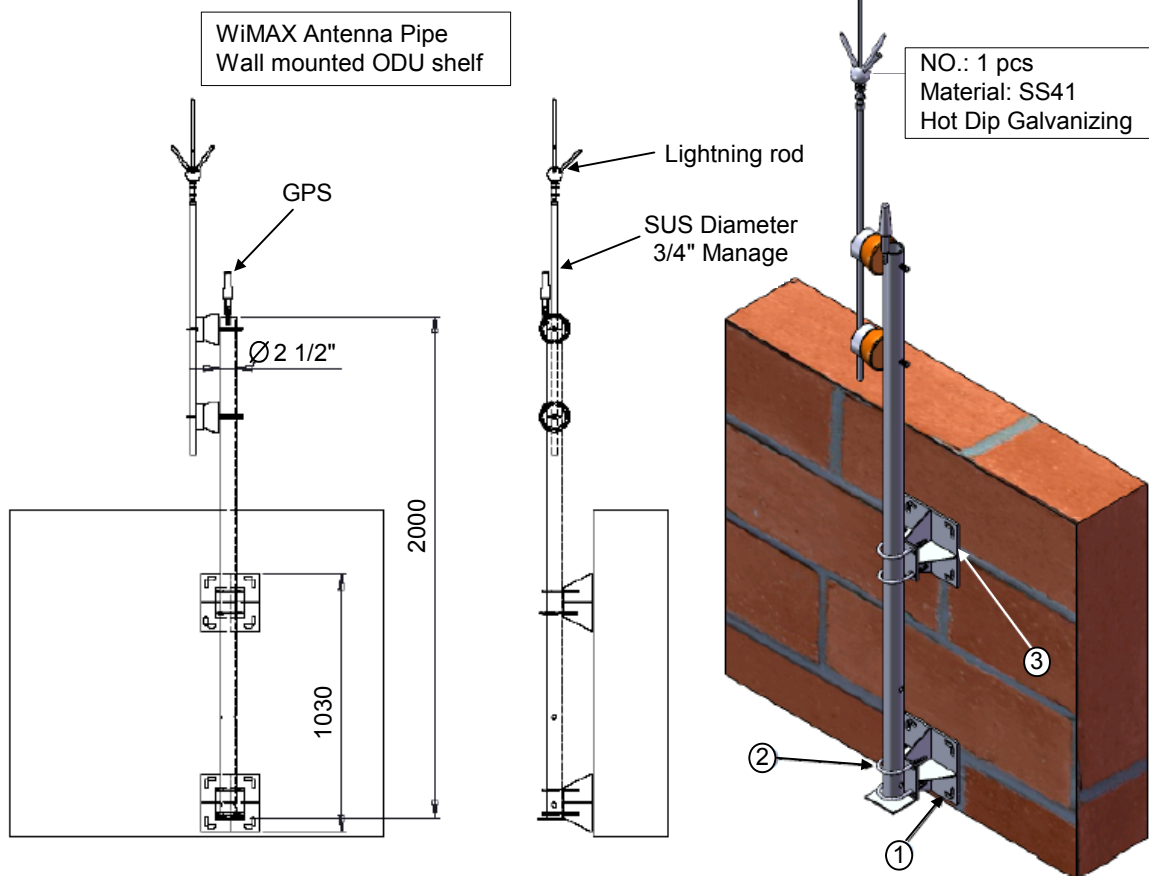

This item weighs 31 kg. (Excluding GPS and Lightning rod)

NO.	Materials
1	SUS 1/2" x 3.5"L - 8pcs, Expansion bolt.
2	SUS 2.5" x 3/4"L - 4pcs, Model U bolt.
3	Fixed base material SS41 Hot Dip Galvanizing.

### 6.7 ODU Mount Structure and Installation Material

The following indicates ODU installation method examples.

(1) ODU on Foundation Type-1

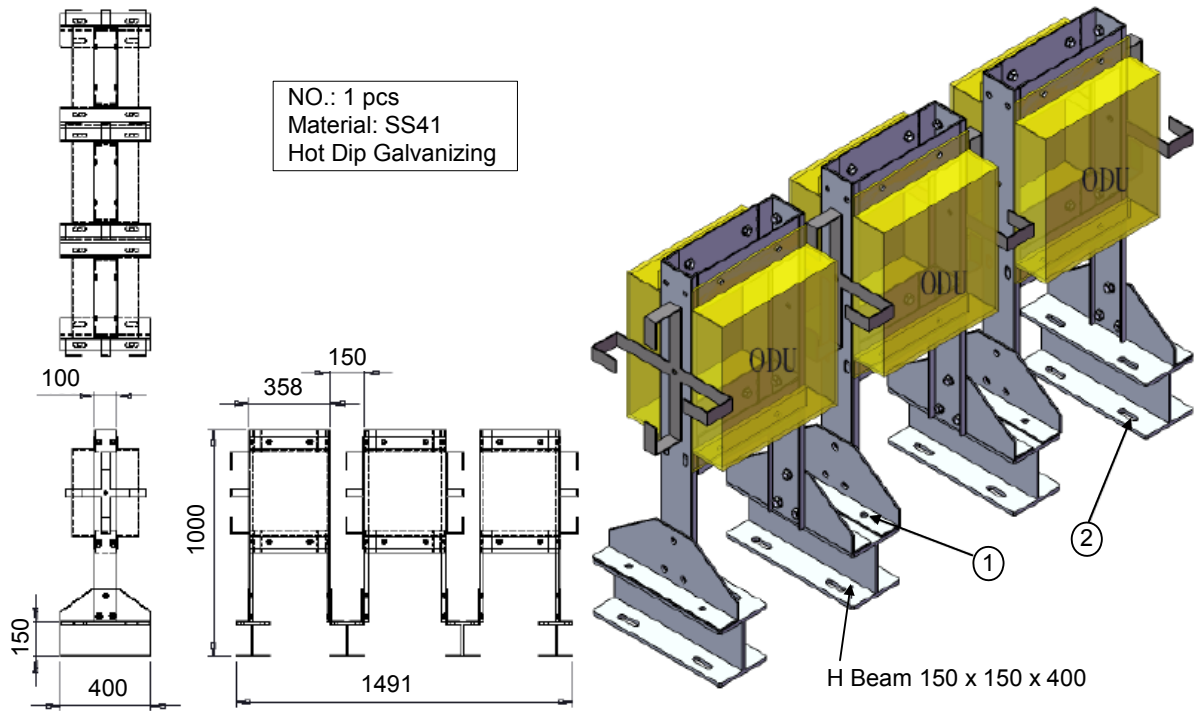

This item weighs 135 kg. (Excluding Equipment and H Beam)

NO.	Materials
1	Hot Dip Galvanizing M12 x 1.75P x 50 - 8pcs.
2	Bearing of ground SUS 1/2" x 3.5"L - 8pcs, Expansion bolt.

(2) ODU on Foundation Type-2

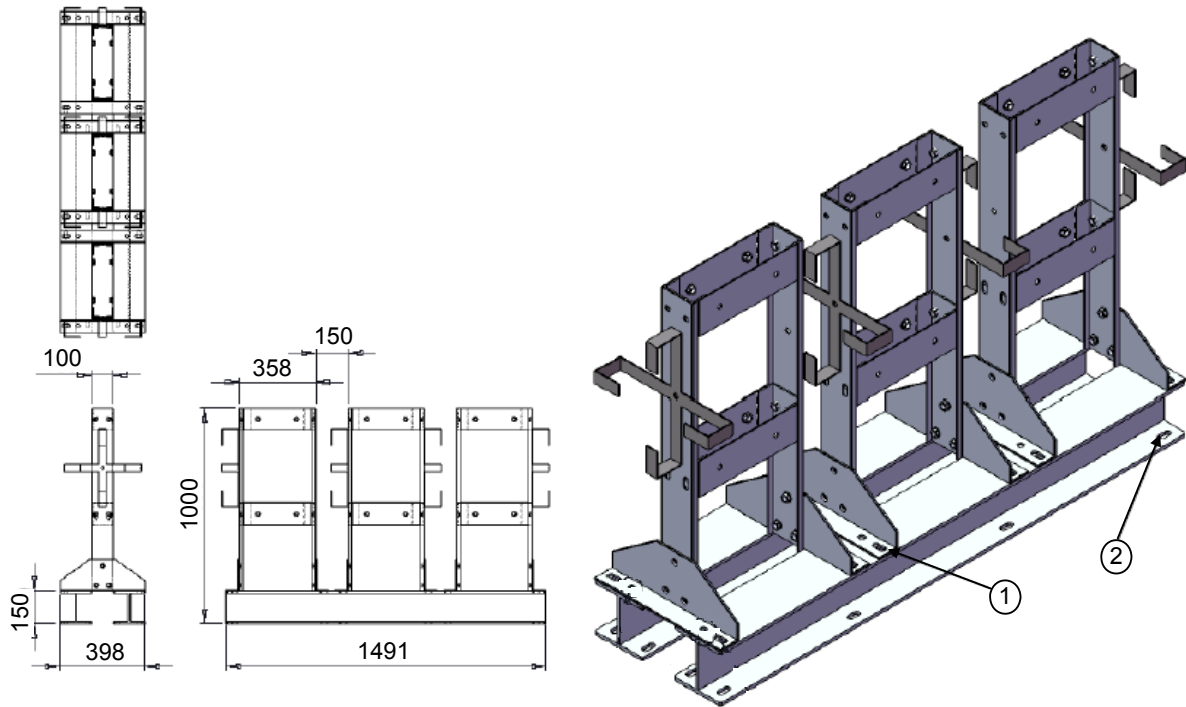

This item weighs 135 kg. (Excluding Equipment and H Beam)

NO.	Materials
1	Hot Dip Galvanizing M12 x 1.75P x 50 - 8pcs.
2	Bearing of ground SUS 1/2" x 3.5"L - 8pcs, Expansion bolt.

(3) Wall Mount Type

NO.: 1 pcs  
Material: SS41  
Hot Dip Galvanizing

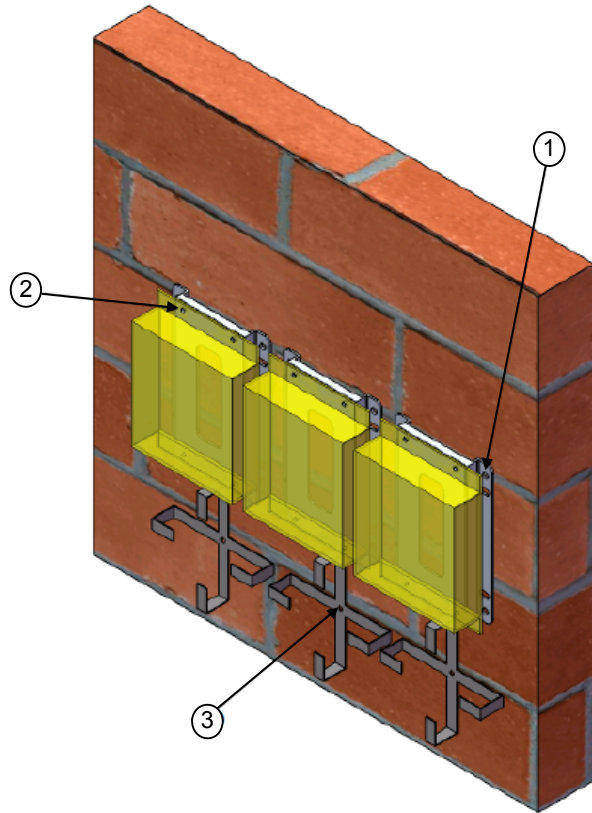
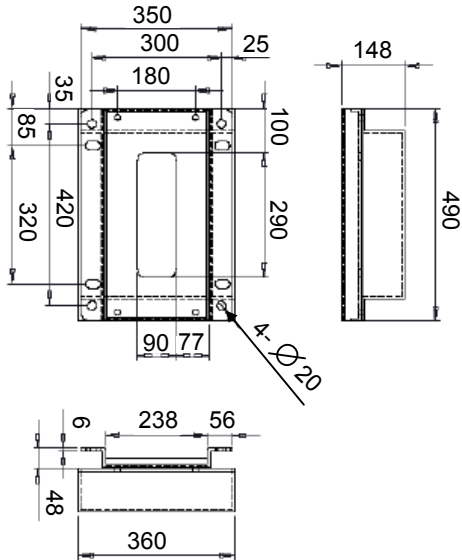

This item weighs 13 kg. (Excluding Equipment)

NO.	Materials
1	SUS 3/8" x 2"L - 4pcs, Expansion bolt.
2	SUS M10 x 1.5P x 20L - 4pcs, Cast the bolt in advance.
3	SUS 3/8" x 2"L - 1pcs, Expansion bolt.



(4) Antenna Pole Mount Type

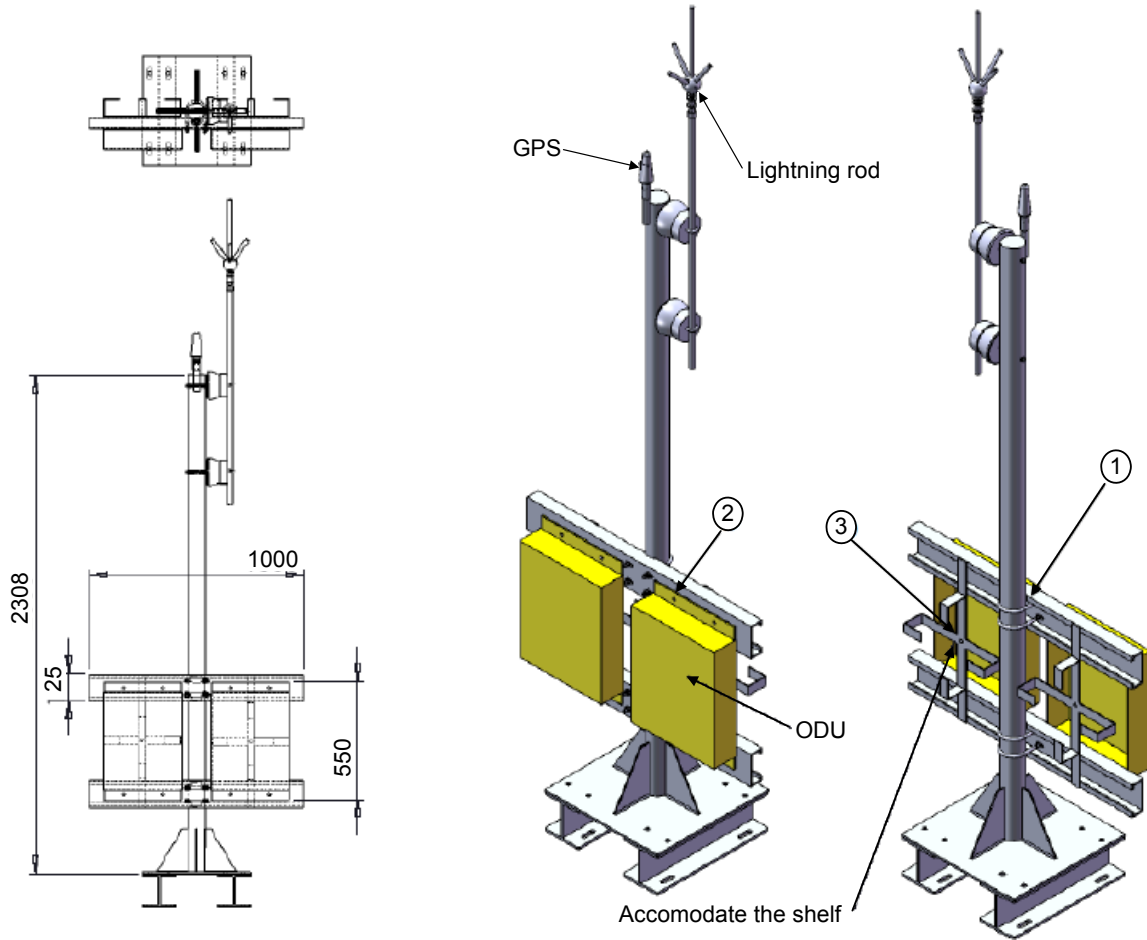

This item weighs 67 kg. (Excluding Equipment and H Beam)

NO.	Materials
1	SUS 3/8" x 2"L - 4pcs, Expansion bolt.
2	SUS M10 x 1.5P x 20L - 4pcs, Cast the bolt in advance.
3	SUS 3/8" x 2"L - 1pcs, Expansion bolt.

**6.8 IDU Mount Structure**

The following indicates the IDU installation method. (Example in which IDU cabinet and battery cabinet are separated) Make sure that the foundation is strong enough to fix the outdoor unit on.

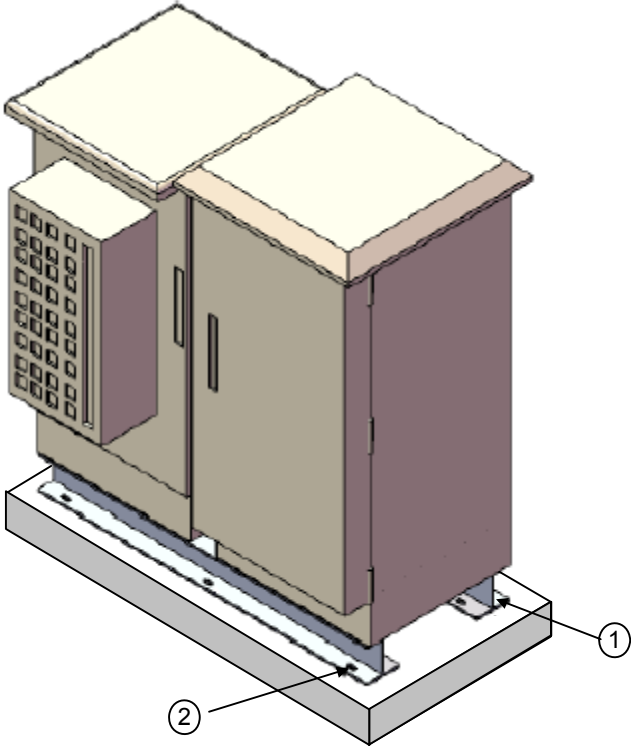

H Beam 150 x 150 x 1500

NO.	Materials
1	Foundation L170 cm x W85 cm x H12 cm.
2	SUS 1/5" x 6"L - 6pcs, Cast the bolt in advance.

### 6.9 Piping and Pipe Rack

The following indicates the various examples of piping.

(1) Wall Mount Type

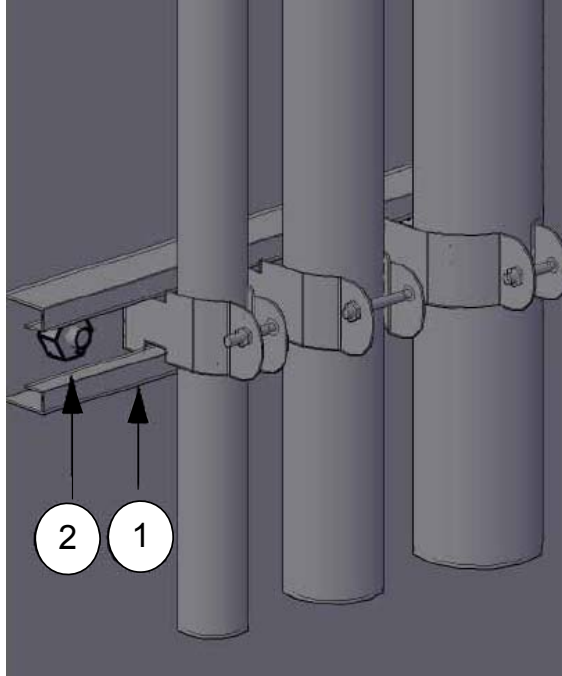

NO.	Materials
1	SUS 304 C25 x 40 x 1.5t.
2	SUS 1/4" x 1/2"L - 2pcs.

(2) Floor Base Type-1

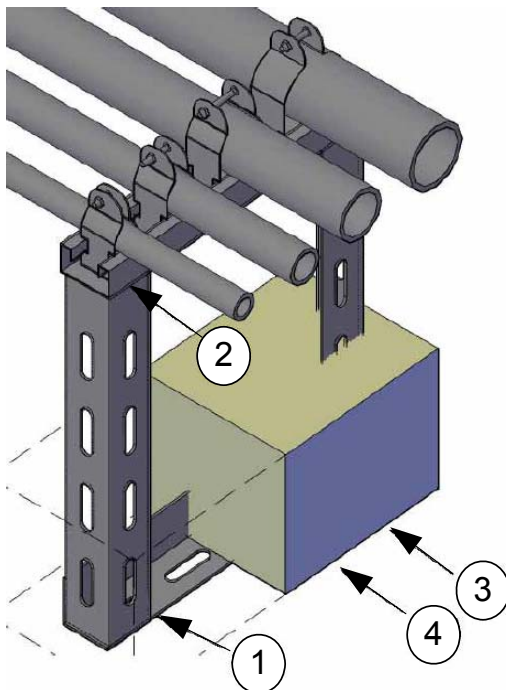

NO.	Materials
1	SUS 304 L40 x 40 x 3t. L Angle w/long hole.
2	SUS 304 C25 x 40 x 1.5t.
3	Foundation L10 cm x W10cm x H12 cm.
4	Waterproof paint of PU elasticity.

(3) Floor Base Type-2

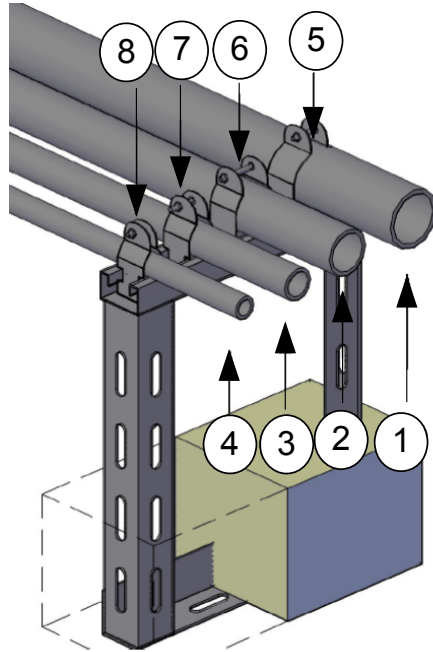

NO.	Materials
1	2"52mm x 4mm
2	1 1/2" 41mm x 3.5mm
3	1"28mm x 3mm
4	3/4"20mm x 3mm
5	SUS 2" x 2mm
6	SUS 1 1/2" x 2mm
7	SUS 1" x 2mm
8	SUS 3/4" x 2mm

(4) Floor Direct Type

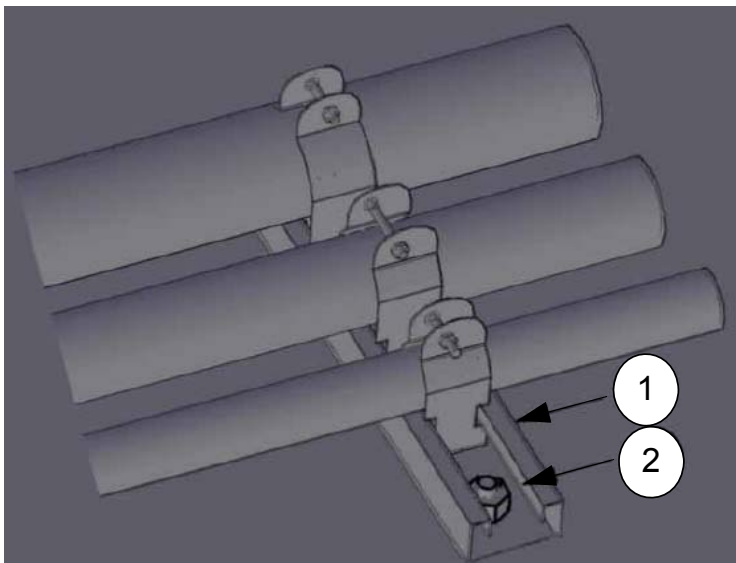

NO.	Materials
1	SUS 304 C25 x 40 x 1.5t.
2	SUS 1/4" x 1/2"L - 2pcs. (mount in floor)