



CloudLab

Tutorial
GEC 22
March 2015



Today's Plan

- Everyone will build their own clouds
 - Using an OpenStack profile supplied by CloudLab
 - Each is independent, with it's own compute and storage resources
- Log in using GENI accounts
- Create a cloud
- Explore the CloudLab interface
- Use your cloud
- Administer your cloud
- **CloudLab is about more than OpenStack**



Prerequisites

- Account on the GENI portal (sent to you as “pre work”)
- Optional, but will make your experience better:
 - SSH keypair associated with your GENI portal account
 - Knowledge of how to use the private SSH key from your laptop
- Known to work best in Chrome and Firefox browsers
- Tablets might work, but not well tested



Crash Course in CloudLab

- Underneath, it's GENI
 - Same APIs, same account system
 - Even many of the same tools
 - Federated (accept each other's accounts, hardware)
- Physical isolation for compute, storage (shared net.*)
- Profiles are one of the key abstractions
 - Defines an environment – hardware (RSpec) / software (images)
 - Each “instance” of a profile is a separate
 - Provide standard environments, and a way of sharing
 - Explicit role for domain experts
- “Instantiate” a profile to make an “Experiment”
 - Lives in a GENI slice

* Can be dedicated in some cases



cloudlab.us/tutorial



CloudLab Hardware





Utah/HP: Very dense





Utah/HP: Low-power ARM64

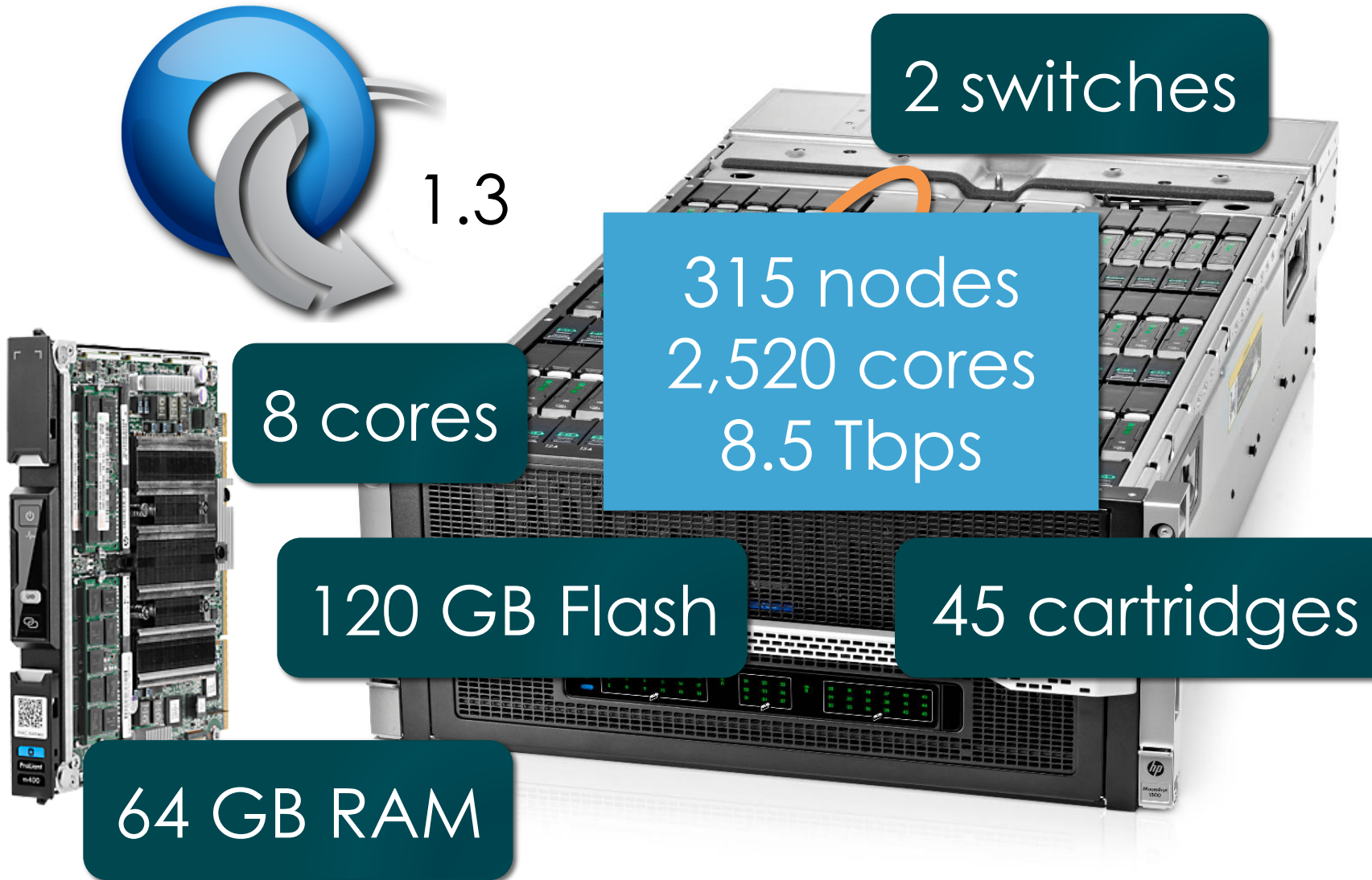



Utah/HP Network: Core switch

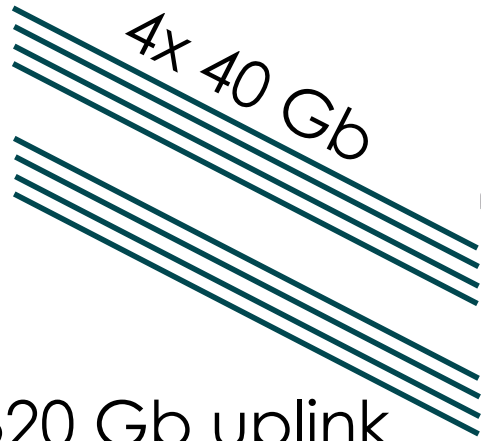

320 Gb uplink

-
-
-

x7

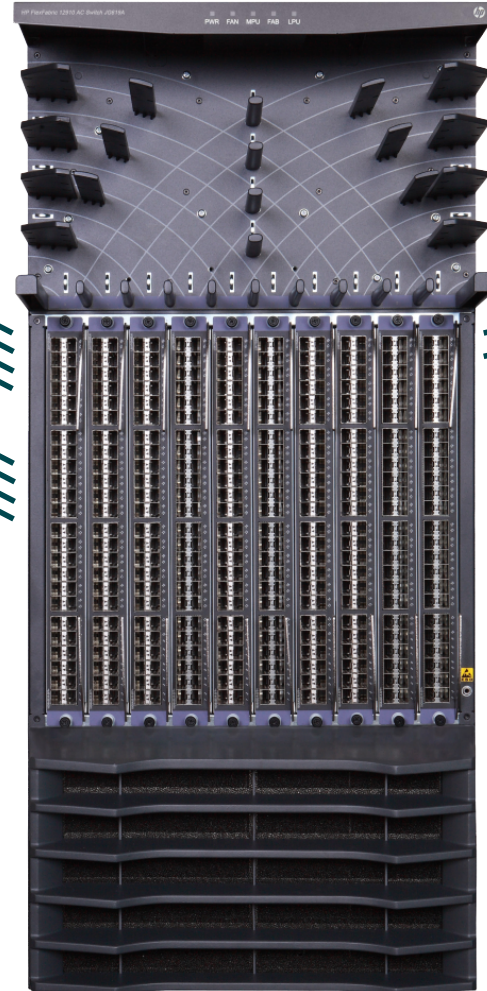



Utah - Suitable for experiments that:

- ... explore power/performance tradeoffs
- ... want instrumentation of power and temperature
- ... want large numbers of nodes and cores
- ... want to experiment with RDMA via RoCE
- ... need bare-metal control over switches
- ... need OpenFlow 1.3
- ... want tight ARM64 platform integration



Wisconsin/Cisco

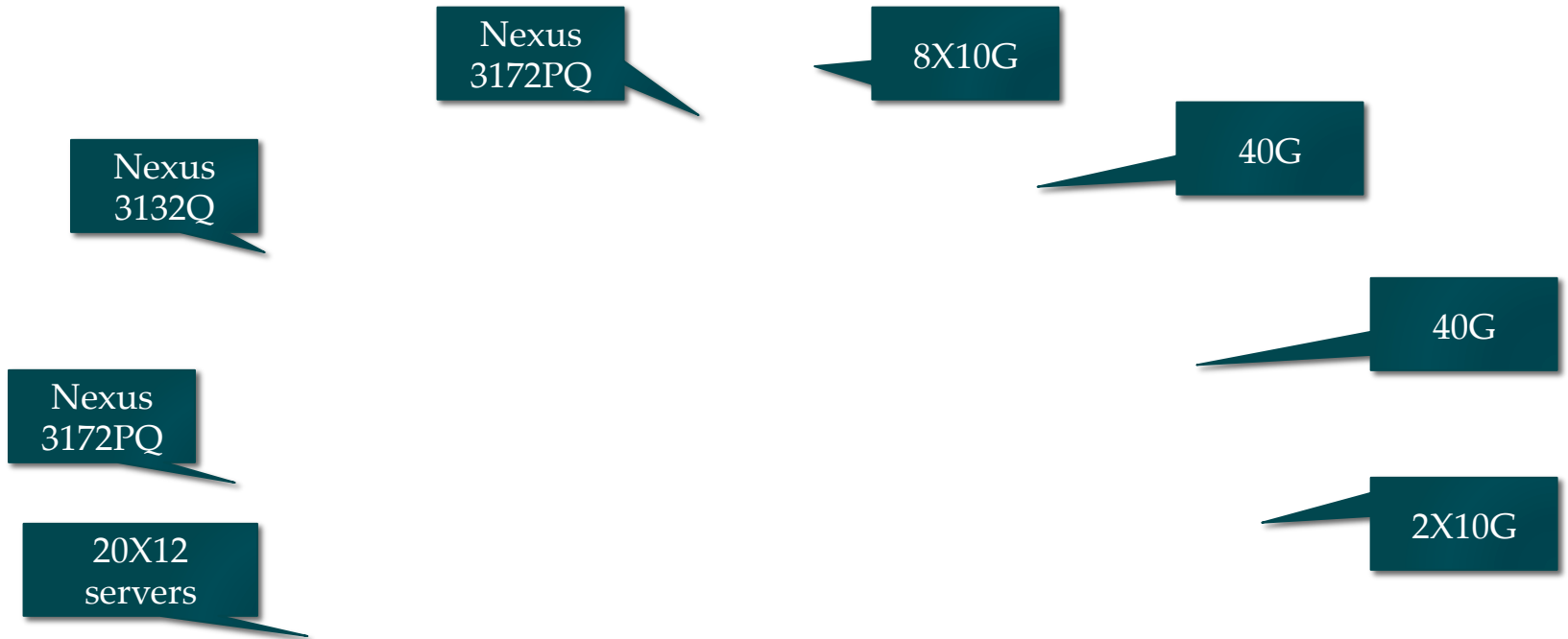



Compute and storage

90X Cisco 220 M4



10X Cisco 240 M4



- 2X 8 cores @ 2.4GHz
 - 128GB RAM
 - 1X 480GB SSD
 - 2X 1.2 TB HDD
- 1X 1TB HDD
 - 12X 3TB HDD
(donated by Seagate)

Over the next year: ≥ 140 additional servers;

Limited number of accelerators, e.g., FPGAs, GPUs (planned)



Networking

Nexus 3132q



Nexus 3172pq



- OF 1.0 (working with Cisco on OF 1.3 support)
- Monitoring of instantaneous queue lengths
- Fine-grained tracing of control plane actions
- Support for multiple virtual router instances per router
- Support for many routing protocols



Experiments supported

Large number of nodes/cores, and bare-metal control over nodes/switches, for sophisticated network/memory/storage research

- ... Network I/O performance, intra-cloud routing (e.g., Conga) and transport (e.g., DCTCP)
- ... Network virtualization (e.g., CloudNaaS)
- ... In-memory big data frameworks (e.g., Spark/Shark)
- ... Cloud-scale resource management and scheduling (e.g., Mesos; Tetris)
- ... New models for Cloud storage (e.g., tiered; flat storage; IOFlow)
- ... New architectures (e.g., RAM Cloud for storage)



Clemson/Dell: High Memory, IB

20 cores/node

1 x 40 Gb IB/node

8 nodes/chassis

2*x 10 GbE OF/node

10 chasses/rack

2*x 1 GbE OF/node



256 GB RAM/node

2 x 1 TB drive/server

* 1 NIC in 1st build



Clemson/Dell Network: IB + 10 GbE

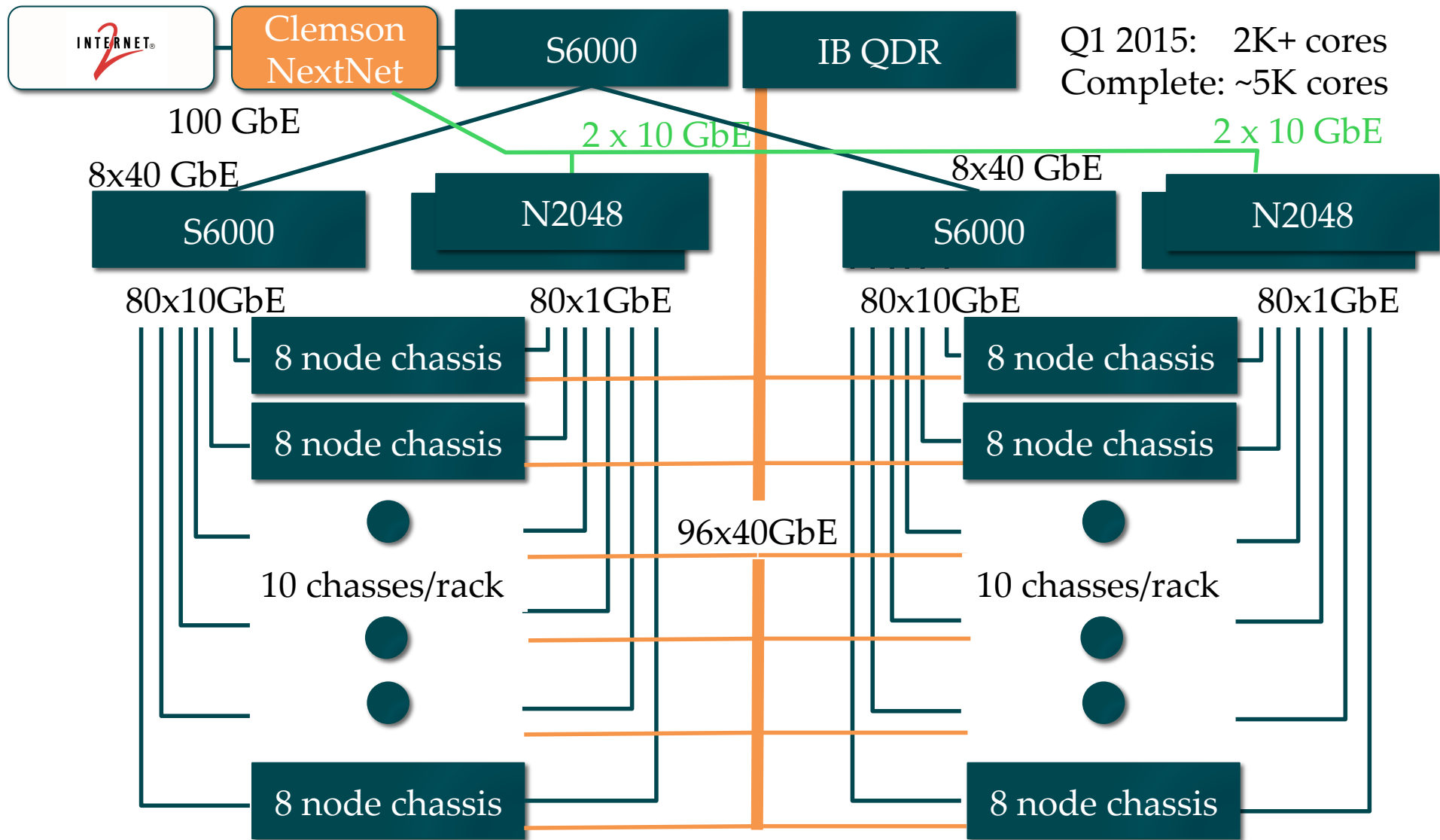



Clemson - Suitable for experiments that:

- ... need large per-core memory
 - e.g., High-res media processing
 - e.g. Hadoop
 - e.g., Network Function Virtualization
- ... want to experiment with IB and/or GbE networks
 - e.g., hybrid HPC with MPI and TCP/IP
 - e.g., cyber physical system
- ... need bare-metal control over switches
- ... need OpenFlow 1.3



Building Profiles





Copy an Existing Profile

The screenshot shows a web browser window at cloudlab.us. The navigation bar includes 'Home', 'Manual', 'Actions', the CloudLab logo, 'rpruser logged in', and a 'Logout' button. A green notification box states 'Your experiment is ready!' with a right-pointing arrow. Below this, the following details are listed:

- URN: urn:publicid:IDN+emulab.net+slice+rpruser-QV992
- State: ready
- Profile: arm64-ubuntu14
- Expires: 12-07T21:24Z (in 16 hours)

At the bottom right of the notification box, there are three buttons: 'Clone' (blue), 'Extend' (green), and 'Terminate' (red). The 'Clone' button is circled in orange. Below the notification box is a blue box labeled 'Profile Instructions' with a right-pointing arrow. At the bottom of the page, there is a tabbed interface with 'Topology View' selected, and other tabs for 'List View', 'Manifest', and 'node' with a close icon.



Use a GUI (Jacks)

The screenshot shows the CloudLab Topology Editor interface. The browser address bar displays `cloudlab.us`. The main window is titled "Topology Editor" and contains a network diagram with a central hub connected to several nodes: `cloud-controller`, `name-node`, `worker-1`, and `worker-5`. The `cloud-controller` node is highlighted with a green border. On the left side, there is a configuration panel with the following sections:

- Custom Type** (checkbox)
- Hardware Type**: (any) (dropdown)
- Custom Hardware** (checkbox)
- Disk Image**: Ubuntu 12.04 LTS 64-bit (dropdown)
- Custom Disk Image** (checkbox)
- Install Scripts**: Add (button)
- URL:** ex: `http://example.com/mystuff.tai` (input field)

On the right side of the diagram area, there are two buttons: "Tidy View" (blue) and "Delete All" (red).



Write Python Code (geni-lib)

```
two-vm.py (~/Desktop) - VIM
import geni.rspec.pg as pg
rspec = pg.Request()

# Create XenVM nodes
node1 = pg.XenVM("node1")
node2 = pg.XenVM("node2")

# Create interfaces for each node.
iface1 = node1.addInterface("if1")
iface2 = node2.addInterface("if2")

rspec.addResource(node1)
rspec.addResource(node2)

# Create a link with the type of LAN.
link = pg.LAN("lan")

# Add both node interfaces to the link.
link.addInterface(iface1)
link.addInterface(iface2)
```



Build From Scratch

The screenshot shows a web browser window with the URL `cloudlab.us`. The page has a dark teal header with navigation links for `Home`, `Manual`, and `Actions`. The user `rpruser` is logged in, with a `Logout` button. The main content area is titled `Create Profile` and contains the following fields and options:

- Name**: A text input field with a help icon.
- Project**: A dropdown menu currently showing `flux`.
- Your rspec**: Three buttons labeled `Choose file`, `Topology`, and `Source`.
- Description**: A large text area with a help icon.
- Instructions**: A large text area with a help icon.
- List on the home page for anyone to view.
- Who can instantiate your profile?**
 - Anyone on the internet (guest users)
 - Only registered users of the website



Sign Up





Sign Up At CloudLab.us

cloudlab.us

Home Manual Sign Up Login

Start Project

Personal Information

Username

Full Name

Email

Institutional Affiliation

Please Select Country

Please Select State

City

Project Information

Join Existing Project Start New Project

Project Name

Project Title (short sentence)

Project Page URL

Project Description (details)