

“Testbeds as a Service”

Building Future Networks

A view into a new GEANT Service

Jerry Sobieski (NORDUnet)

GEC 19

Atlanta, Mar 18, 2014

From Innovation to Infrastructure



- Network Innovation requires testing to prove out...
 - Testing in live networks can have unintended effects on non-combatants. Other users and network providers don't like being **crash test dummies.**
 - "Production" environments have the required scale but are *highly* risk averse.



How do we evolve innovations from concept to production with minimal risk to infrastructure, services, and applications already in place providing on-going stable and reliable services?

- The network research community needs “Laboratories” to test novel concepts ...



- Constructed from stable underlying infrastructure
- Allow high risk experiments to be carried out...
- Yet prevent unexpected or errant behaviour from interfering with production services or other research activities
- Provide reliable and effective work environment for the researcher
- Enable a broad range of innovation – i.e. technology agnostic
- Agile: Ability to rapidly prototype new ideas or integrate new results
- Scalable: Ability to construct large scale test environments
- These laboratories must be able to duplicate real world scenarios such that research results are useful and valid

GN3+SA2 Testbeds as a Service

“TaaS”



● SA2 key service capabilities:

- **Dynamic “Packet” Testbeds** – *dynamically allocated, virtual networks* provisioned over production transport and switching infrastructure with a pan-European footprint.
 - *Under control of the researcher*
 - *Insulated to prevent collateral damage*
 - *Flexible user defined network resources, can morph as necessary*
 - *Extensible support for novel hardware*
- **“Dark Fiber” Testbeds** – photonic testbeds over dark/dim fiber along long haul routes between a limited set of major EU metro areas.
 - *Virtualization of these resources is hard...but we’ll see...*
- **“GOFF”** – **a prototype OF testbed** originally fielded by GN3-JRA2
 - *Software emulated OpenFlow switching (OVS)*
 - *Bridge service as TaaS ramps up...*

● SA2 is a **GEANT Production Service**

- The test beds it creates are expected to be reliable and consistently available.
- Which means the SA2 support processes must be stable and secure
- This integrated “multi-species” virtualization represents new technology and continues to evolve in the community ... There continues to be many research efforts, and many emerging frameworks and service models...

A Brief Dive into the Internals:



The TaaS Architecture treats all [testbed] networks as graphs

Testbed “Alpha” Description

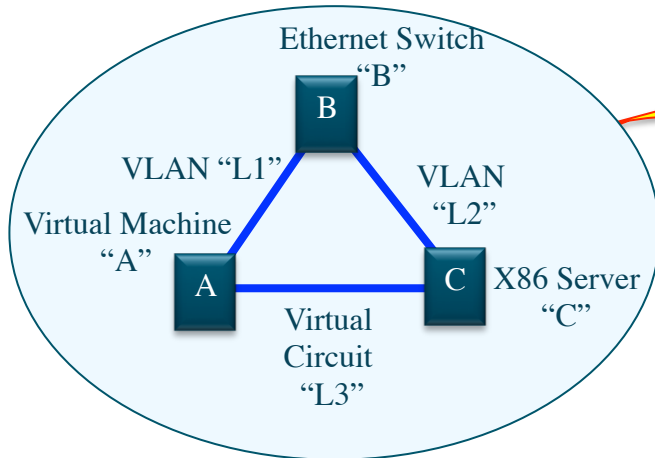

Internally, TaaS represents all testbed components as virtual “resources” with data flow ports. User specified Port adjacency relations define the testbed topology.

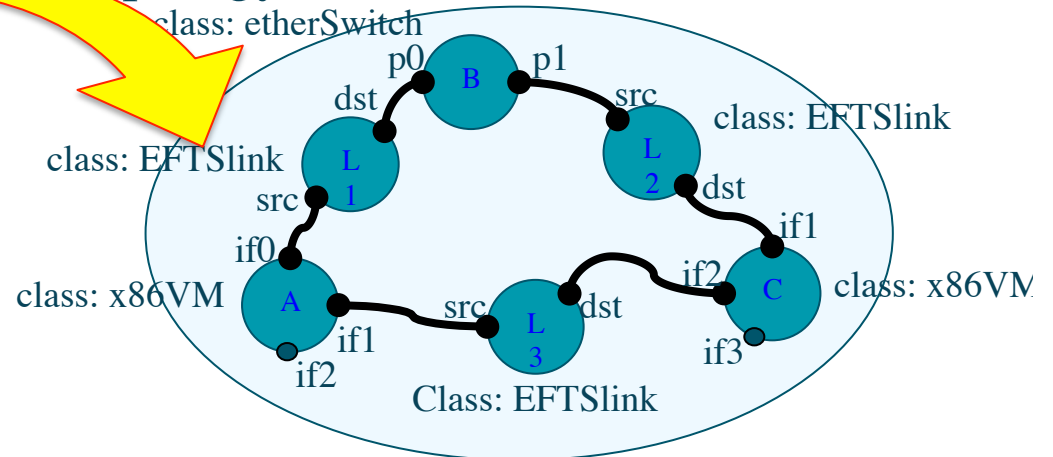

Data plane resource graph

TaaS Dynamic Testbed Provisioning - How it works



Network testbed concept to test brilliant idea

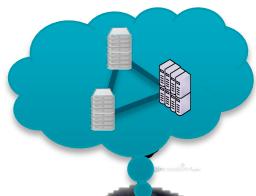

Researcher logs in, builds a testbed description via a web GUI

Researcher has a brilliant idea



Testbed Template doc "BrilliantIdea" network

```
Resource A
port p0, p1;
Resource B
port out1,
out2;
Adj B/out1==A
p0;
```

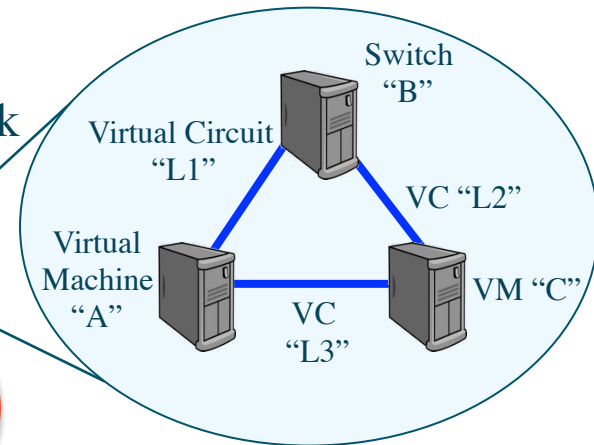

Resource Manager allocates resources

Testbed is activated and user controls it via the TCA

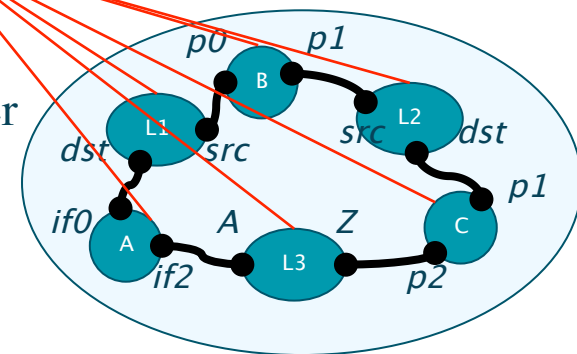

GEANT “Testbeds as a Service” Virtualization, Management, and Control Layers

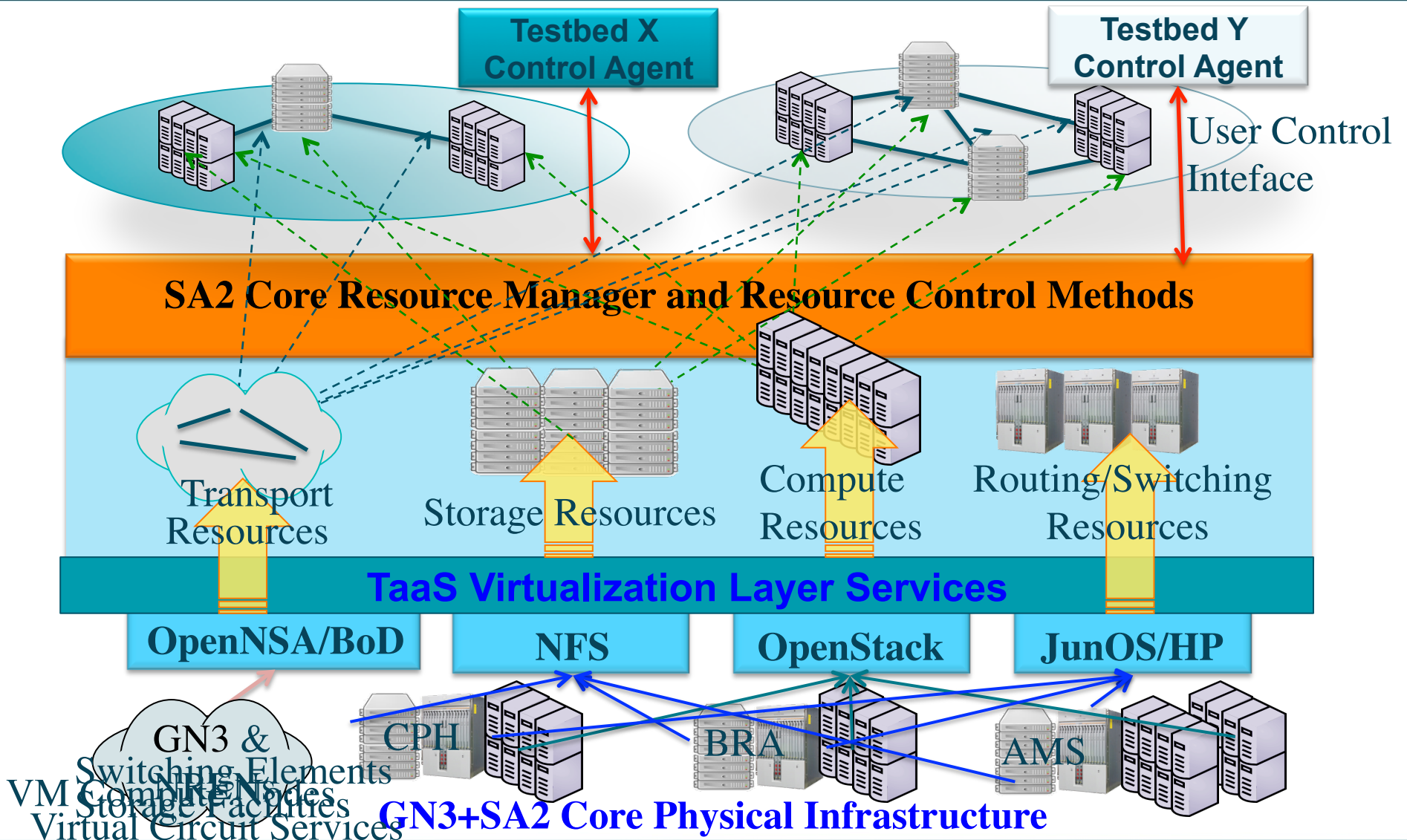

Resource Specific Testbed Control Primitives



- Each Resource Class defines methods (control primitives) that translate high level TaaS control semantics to resource specific command sequences.
 - Each resource class *must* implement the gang of five..
 - *Reserve()*
 - *Activate()*
 - *Query()*
 - *Deactivate()*
 - *Release()*
 - Each resource class may define additional control primitives/ semantics that may be specific to that class of resource only
- New resources classes may be introduced into the TaaS service by developing these control primitives

Resource Roadmap



● Processing Resources

- **Virtual Machine (v1.0)**
- **Virtual OpenFlow Fabric (v1.0)**
- Bare Metal Nodes (v1.1)
- Virtual Switches
- Virtual Routers (v1.1)

● Transport Resources

- **Virtual Circuits (v1.0)** – Ethernet framed endpoints, VLAN deliniated
- BE Broadcast domains (v1.1)
- Waves (v1.x)
- Photonic spectrum (v2.0)

● Other Resources

- IP Subnet – User access gateway
- Wifi / mobile

SA2 Testbeds

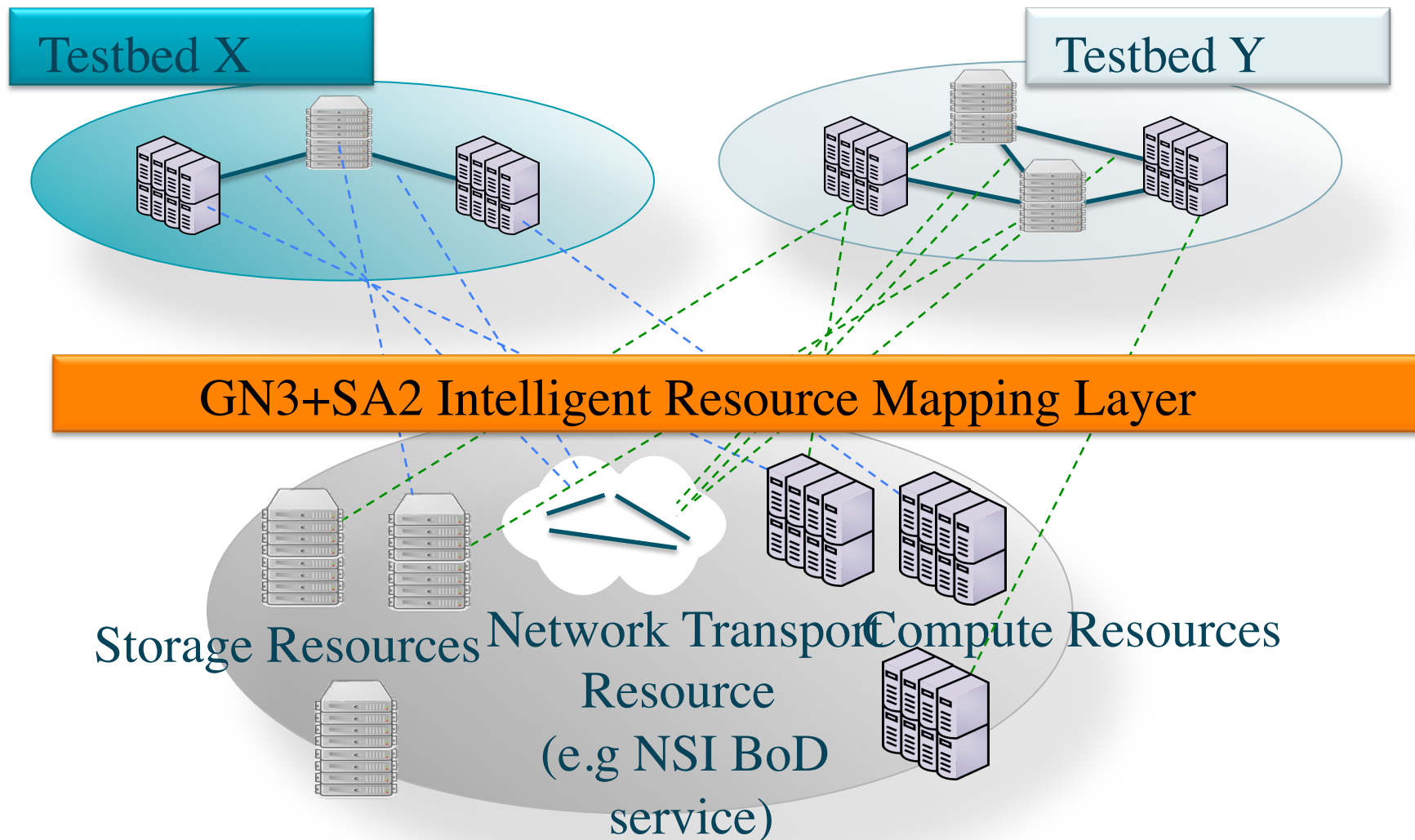

Geographically distributed physical resource pool

SA2 Testbeds- External Access

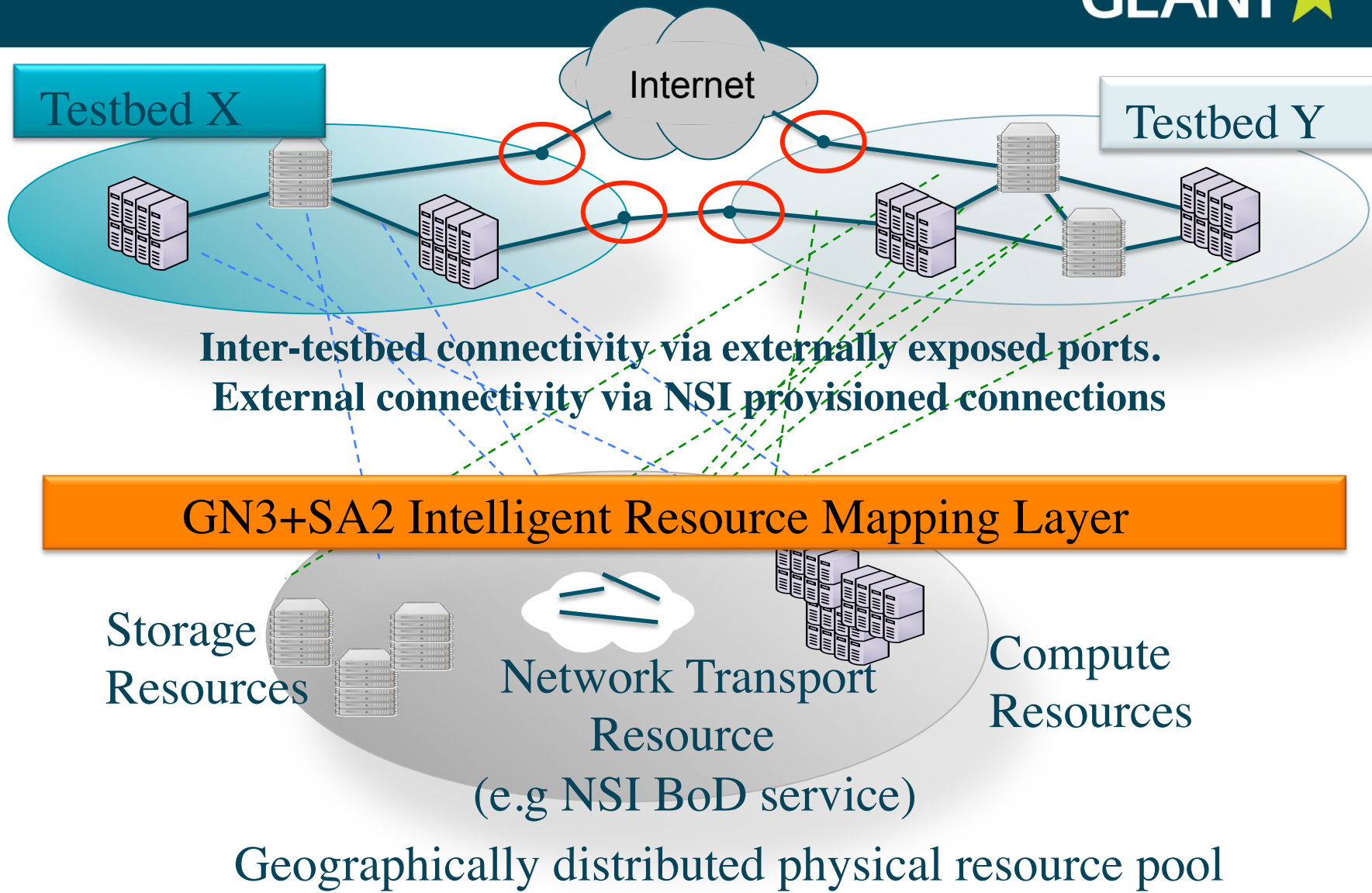

SA2 Multi-domain Testbeds (Phase 2)

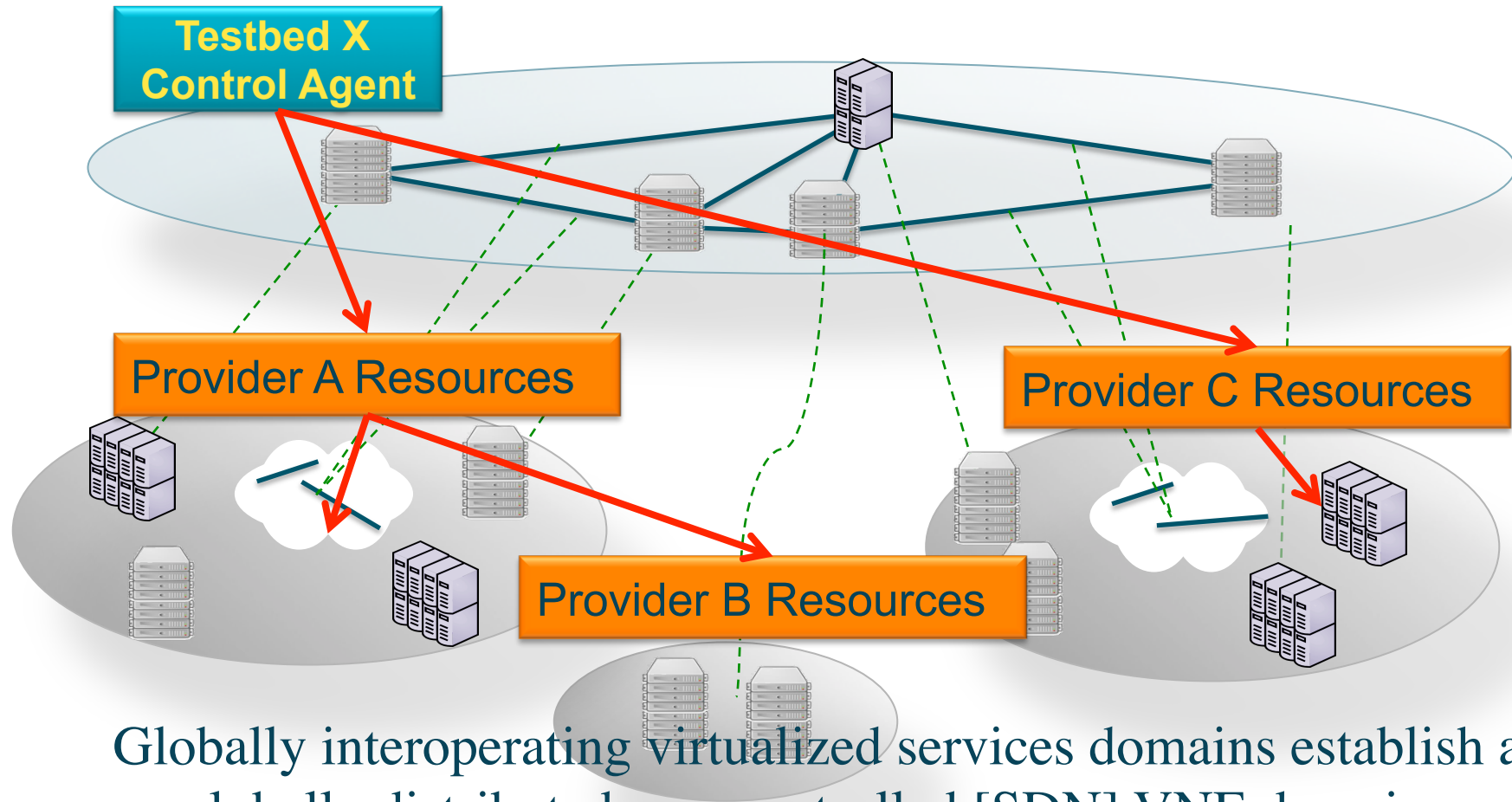

Globally interoperating virtualized services domains establish a globally distributed user controlled [SDN] VNE domain... Promotes deterministic Operations Monitoring and Performance Verification

GN3 OpenFlow Facility

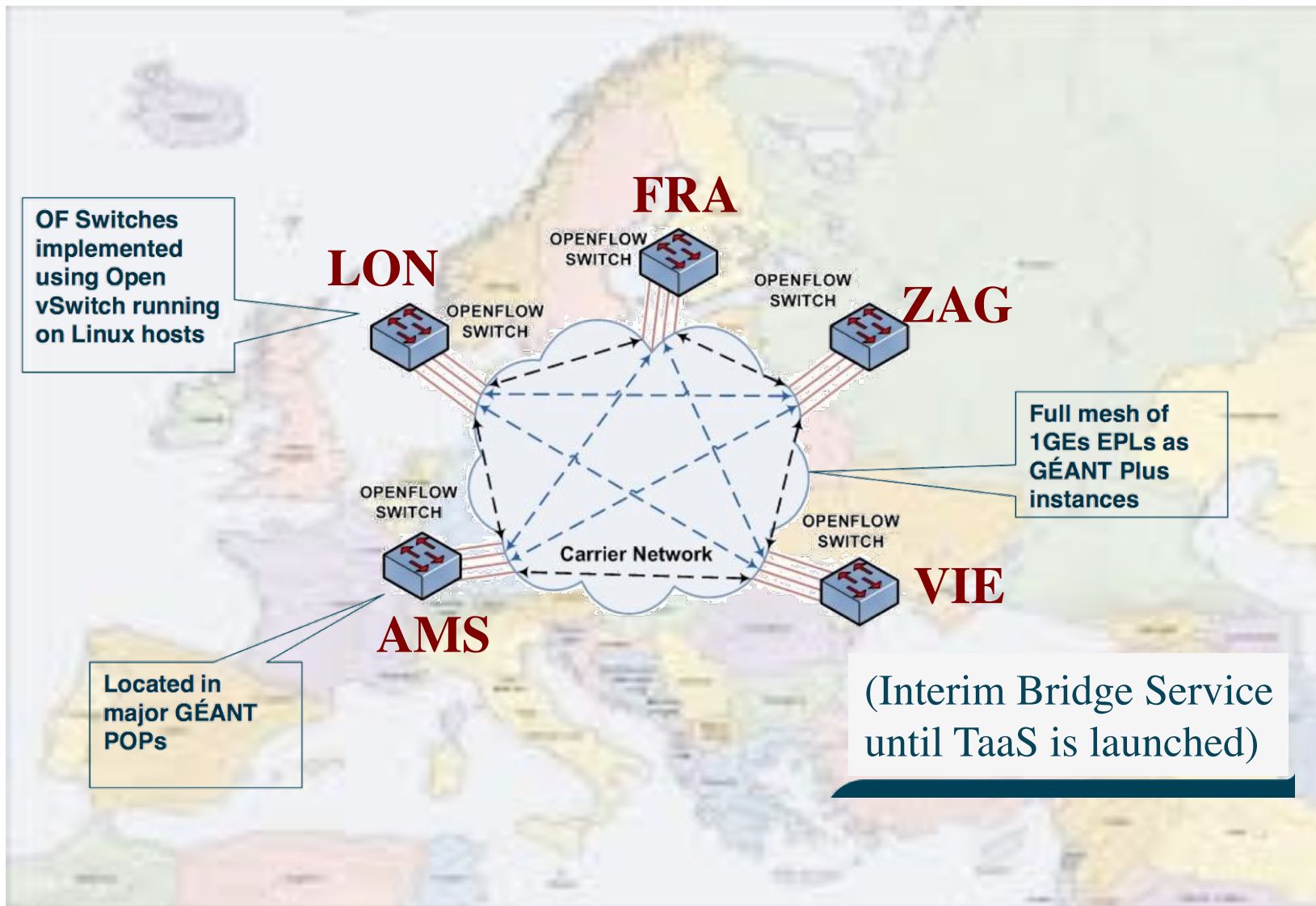

TaaS Deployment Plan (as of Jan 2014)

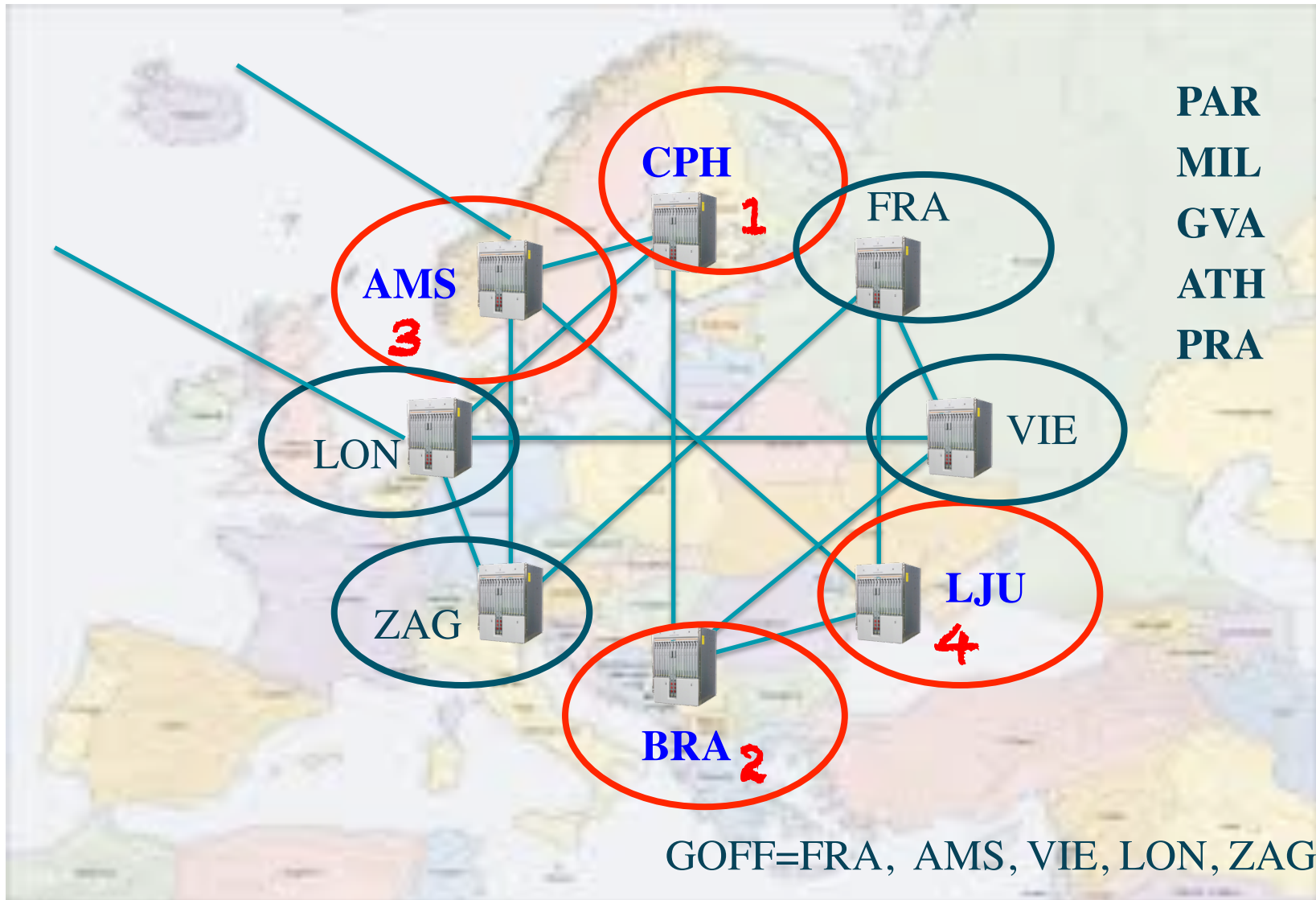

TaaS initial multi-domain interconnection concept



NSI Connection Services create multi-domain transparent data planes

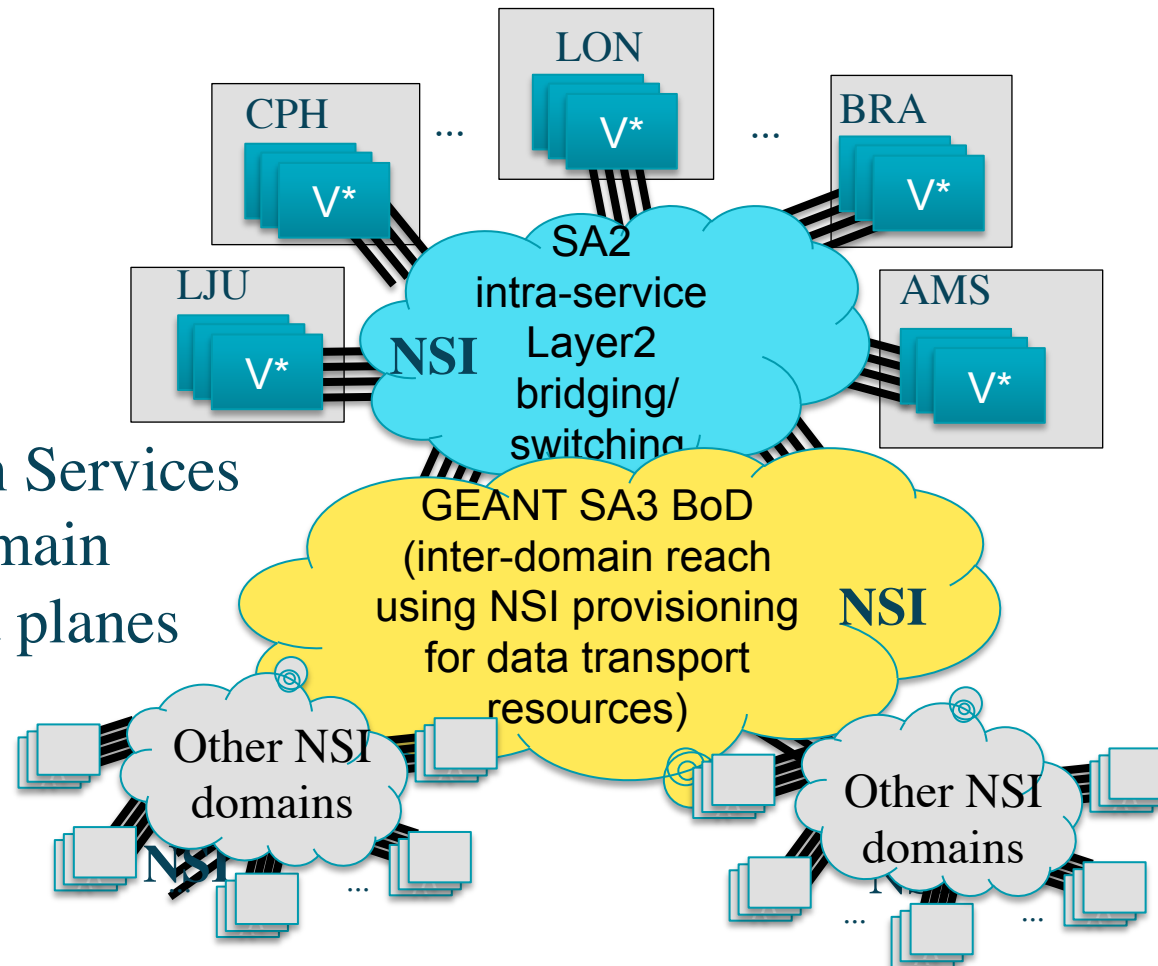

- Testbeds (virtual network environments/slices) must extend/scale globally - yet preserve security, insulation, control, privacy, etc
- GEANT SA2-T4 is exploring a strategy
 - EU deployment within NRENs and Campus service implementations
 - Inter-domain interoperation with similar projects in other international regions
 - US/NA (*Internet2 AL2S, GENI*)
 - SA
 - APAC
 - Common service model, common inter-domain architecture, consensus protocol(s), ...



TaaS Features Roadmap



● TaaS v1.0 Full – April 2014

- Resources: new VM flavors (e.g. “thin” VMs)
- Begin migrating GOFF users to TaaS
- NAS storage, 10Gbps VCs,...

● TaaS 1.1 Sep 2014

- Virtual Router resources – specifics TBD
 - *Juniper?, OpenFlow, 10+ Gbps,...* (TBD!)
- Interface with BoD (SA3) and NRENs for VCs
- Bare Metal servers (blade servers (??))
- “Cloud”/Datacenter integration
- Initial multi-domain resource brokering

● TaaS 2.0 CY15-Q1

● GN4 - 2015-2022 (!) – Project being defined now...

SA2 TaaS Conspirators:



● GARR

● PSNC

● TERENA

● DANTE

● CESnet

● AMRES

● GRnet

● RedIRIS

● DFN

● RENETER

● HEAnet

● NIIFI

● NORDUnet



SA2 Ring Leaders



- SA2 Activity Leader: **Jerry Sobieski (NORDUnet)**



The [actual] important people:

- T1: Hardware and Systems Eng TL: **Dom Tailor (DANTE)**
- T2: Software Development TL: **Blazej Pietrzak (PSNC)**
- T3: Service Management TL: **Peter Szegedi (TERENA)**
- T4: Multi-Domain Interoperability TL: **Fabio Farina (GARR)**



Dom Tailor



Blazej Pietrzak



Peter Szegedi



Fabio Farina

Questions?

