

SPP Project Status

June 30, 2009

Jon Turner
Applied Research Lab
Washington University

www.arl.wustl.edu

Project Objectives

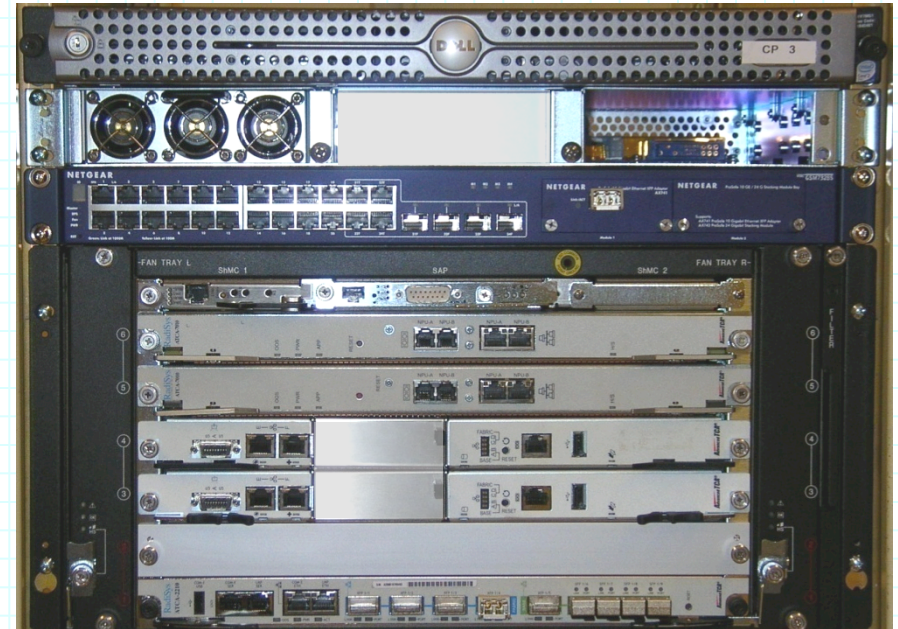
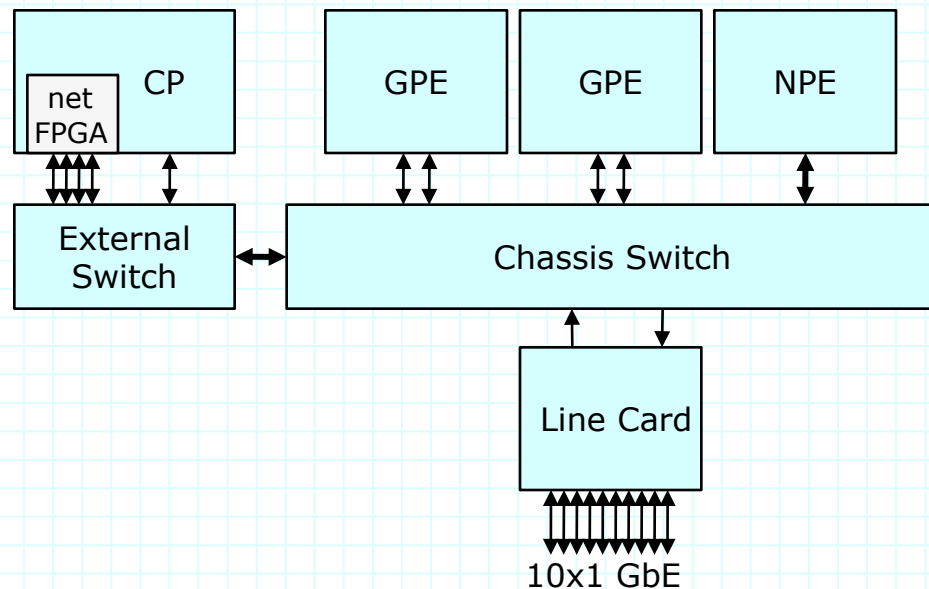

- Deploy five experimental *overlay hosting platforms*
 - » located at Internet 2 PoPs
 - » compatible with PlanetLab, moving to GENI control framework
 - » performance characteristics suitable for service deployment
 - integrated system architecture with multiple server blades
 - shared NP-based server blades for fast-path packet processing
- Demonstrate multiple applications

Planned Deployment

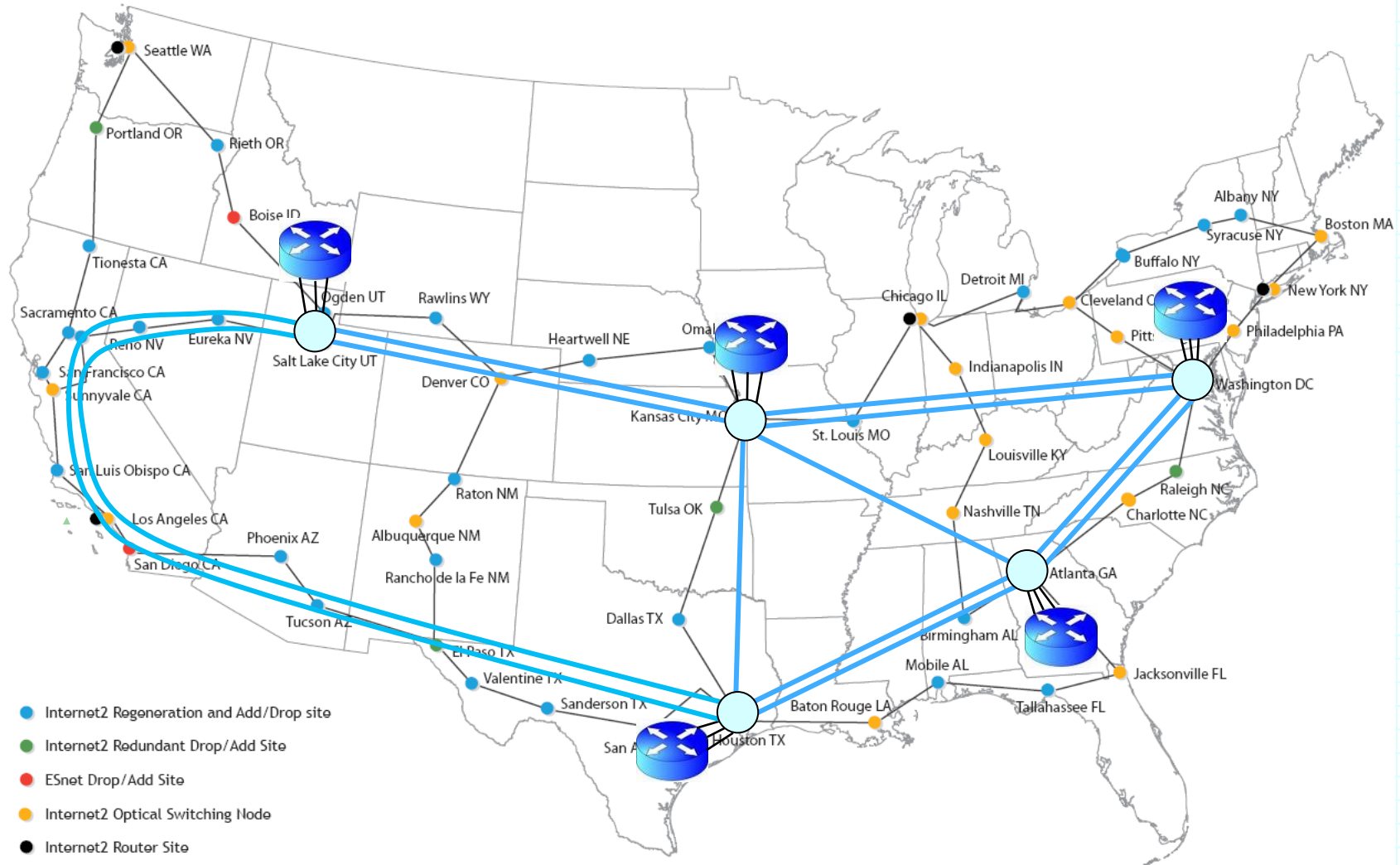

Specific Project Goals (all three years)

- Acquisition, assembly, configuration and testing of five SPP nodes
- Deployment of SPP nodes in Internet2 national network
- User training and support
- Consulting and development of new code options
- System software to support GENI-compatible control interface

Year 1 Deliverables

- Develop initial version of component interface software “matching GENI framework” and demonstrate on SPP nodes in WU lab (by month 6)
- Deploy two SPP nodes in Internet2 (by month 9)
- Make initial SPP deployment available for limited use by external researchers (by month 12)
- Delivery of preliminary architecture and design documentation to GPO (by month 9)
- Delivery of SPP component manager interface documentation to GPO (by month 12)
- Develop web site for user documentation and feedback (by month 12)

Current Activities

- Public Demonstration at GEC 4
- Completion of Initial Version of Reservation Software
- Preparation for Deployment
- System Architecture Document
- User Documentation
- Work out SPP-rspec content/semantics
- Flow Monitoring
- Version 2 of Network Processor Datapath Software
- Preliminary Work on New Fast Path Code Option
- System Integration/Bug Fixes

Year 2 Deliverables

- Carry-over from year 1
- Continue development of component interface software
 - » Integrate fast path and inter-node link bandwidth reservation into the GENI management framework
 - » use rspecs for making multi-node reservations
- Develop user documentation and tutorial material
 - » includes tutorials at GECs
- Provide operational support for deployed systems
- Provide two sample applications using SPP fast paths
 - » provide complete, documented source code for use by researchers
- Deliver interface documentation for of SPP component manager software

Other Things We Might Do (as time permits)

- Implement control software for NetFPGAs
- Terminate VLANs to MAX, GpENI, Stanford (?)
 - » physical connectivity? need to move fast
 - » what do VLANs connect to?
 - » static or dynamic
- Mount cool demos at GECs
 - » e.g. Openflow in a slice
- Demonstrate slice management using GUSH & Raven
- Eliminating IP tunnels where L2 connections exist
- Transition management to IU group
- Expand NP capabilities
 - » Netronome 40 cores on low cost PCIx card